



ohmic instruments co.

508 August St. Easton, MD
21601

Voice: (410) 820-5111

Fax: (410) 822-9633

www.ohmicinstruments.com

UPS-500
RESISTIVE RELATIVE HUMIDITY SENSOR
APPLICATION NOTES

© 2006 Ohmic Instruments Company, Easton, MD

UPS-500 PRECAUTIONS

DC Voltage:

Never apply a DC voltage to the UPS-500. Only a symmetrical AC excitation voltage under 6V AC should be used. The nominal frequency should be between 33 and 1000Hz. The excitation can be a sawtooth, square, or sine wave with no DC bias. DC voltage (including DC pulses) will polarize the sensor, resulting in an irreversible shift. Never connect the sensor to an ohmmeter.

Condensation, Fog, Mist or Liquid Water:

The polymer coating of the UPS-500 is water soluble; therefore, exposure to condensation, mist fog, or liquid water should be avoided. Exposure to these conditions will cause an irreversible shift.

Temperature Limits:

The operating temperature limit for the UPS-500 is -4°F to $+140^{\circ}\text{F}$.

Chemical Vapors:

Alcohols and other polar compounds typically cause a temporary shift. Reactive chemicals such as sulfides, halogens, mercury vapor, acids and ketones should be avoided. Hydrocarbons or oil mist tend to condense as a varnish which slows the response time of the sensor.

Physical Contaminants:

When used in environments with dust and oil mist, a filter must be utilized. The UPS-500 may be used at high static pressures (>6000 psi). High absolute vacuum should be avoided.

Installation of Sensors:

Sensors must be hand soldered. A heat sink should be used on the sensor legs when soldering to prevent excessive heat from reaching the pad on the sensor body. Carefully clean solder excess with a solder cleaner, but do not get any cleaner on the sensor itself.

UPS-500 RESISTIVE HUMIDITY SENSORS

Temperature Compensation

The average coefficient for temperature compensation of the UPS-500 sensor works out to $-0.7\% \text{ RH}/^{\circ}\text{C}$ ($-0.4\% \text{ RH}/^{\circ}\text{F}$). The correction factor is computed with the expression:

$$C = -0.7(T-25)$$

C = the correction factor in percent to be algebraically added.

T = the temperature in $^{\circ}\text{C}$.

$$C = -0.4(T-77)$$

C = the correction factor in percent to be algebraically added.

T = the temperature in $^{\circ}\text{F}$.

For example: A sensor in an environmental condition of 35°C and 50% RH provides an impedance of $27\text{K}\Omega$. This impedance with reference to 25°C equals about 57% RH, therefore 7% must be subtracted to obtain the correct reading. Likewise a sensor in an environmental condition of 15°C and 50% RH will read an impedance of $150\text{K}\Omega$. This impedance when referenced to 25°C equals about 43% RH, therefore 7% must be added. The temperature coefficient is optimized for the median %RH and temperature range between 30 and 70% RH and 15 to 35°C . When the sensor is operated outside these limits the accuracy of the coefficient decreases.

UPS-500 Equation

With microprocessor-based circuitry an alternative method of converting the sensor's impedance to %RH with respect to temperature is expressed as:

$$\%RH = A(CZ)^{\frac{T+459.7}{D(T+459.7)+B}} \quad \text{OR: } \%RH = A\{(CZ)^{[(T+459.7)/(D(T+459.7)+B)]}\}$$

Z = the impedance of the UPS-500 sensor in MΩ.

A, B, C, D = constants for specific impedance ranges (see table below).

T = dry bulb temperature in °F.

Z in MΩ	A	B	C	D
30 < Z	2.795953	-2346.986	0.1299848	4.067295
12 < Z <= 30	10.83324	-2368.839	28.18587	3.016073
5 < Z <= 12	29.29039	-2426.034	49399.25	1.993527
0.05 < Z <= 5	2.79711	-7813.2	100848.4	9.437572
0.005 < Z <= 0.05	5.729313	-5357.106	19934420	4.242907
Z <= 0.005	3.158756	-6368.854	1247857	5.748199

The equation is valid over the temperature range of 41 to 113°F (5 to 45°C). Agreement to the empirical data is about 2% from 25 to 90% RH and 3% from 10 to 25% RH.

5°C

UPS-500 DATA CHARTS

%RH	OHMS	°C		%RH	OHMS	°C		%RH	OHMS	°C
10	60.69E+6	5		37	5.25E+6	5		64	88.40E+3	5
11	57.21E+6	5		38	2.20E+6	5		65	80.34E+3	5
12	54.20E+6	5		39	1.88E+6	5		66	73.12E+3	5
13	51.58E+6	5		40	1.60E+6	5		67	66.65E+3	5
14	49.26E+6	5		41	1.38E+6	5		68	60.83E+3	5
15	47.20E+6	5		42	1.19E+6	5		69	55.59E+3	5
16	45.35E+6	5		43	1.03E+6	5		70	50.87E+3	5
17	43.67E+6	5		44	891.25E+3	5		71	35.46E+3	5
18	42.15E+6	5		45	775.91E+3	5		72	32.40E+3	5
19	40.76E+6	5		46	677.56E+3	5		73	29.64E+3	5
20	39.49E+6	5		47	593.40E+3	5		74	27.15E+3	5
21	38.31E+6	5		48	521.15E+3	5		75	24.90E+3	5
22	37.22E+6	5		49	458.92E+3	5		76	22.86E+3	5
23	36.21E+6	5		50	405.16E+3	5		77	21.01E+3	5
24	35.27E+6	5		51	358.58E+3	5		78	19.33E+3	5
25	34.38E+6	5		52	318.11E+3	5		79	17.81E+3	5
26	33.56E+6	5		53	282.86E+3	5		80	16.42E+3	5
27	32.78E+6	5		54	252.06E+3	5		81	15.16E+3	5
28	32.05E+6	5		55	225.09E+3	5		82	14.00E+3	5
29	31.36E+6	5		56	201.42E+3	5		83	12.95E+3	5
30	30.71E+6	5		57	180.59E+3	5		84	11.99E+3	5
31	30.09E+6	5		58	162.22E+3	5		85	11.11E+3	5
32	14.90E+6	5		59	145.99E+3	5		86	10.30E+3	5
33	14.14E+6	5		60	131.62E+3	5		87	9.56E+3	5
34	13.43E+6	5		61	118.86E+3	5		88	8.88E+3	5
35	12.78E+6	5		62	107.52E+3	5		89	8.26E+3	5
36	12.18E+6	5		63	97.42E+3	5		90	7.68E+3	5

UPS-500 DATA CHARTS

15°C

%RH	OHMS	°C		%RH	OHMS	°C		%RH	OHMS	°C
10	35.30E+6	15		37	867.66E+3	15		64	30.69E+3	15
11	33.80E+6	15		38	746.79E+3	15		65	27.93E+3	15
12	32.48E+6	15		39	645.26E+3	15		66	25.46E+3	15
13	31.31E+6	15		40	559.61E+3	15		67	23.23E+3	15
14	30.27E+6	15		41	487.03E+3	15		68	21.23E+3	15
15	27.06E+6	15		42	425.29E+3	15		69	19.43E+3	15
16	24.49E+6	15		43	372.56E+3	15		70	17.80E+3	15
17	22.29E+6	15		44	327.36E+3	15		71	16.33E+3	15
18	20.40E+6	15		45	288.49E+3	15		72	15.00E+3	15
19	18.76E+6	15		46	254.93E+3	15		73	13.79E+3	15
20	17.32E+6	15		47	225.88E+3	15		74	12.70E+3	15
21	16.06E+6	15		48	200.66E+3	15		75	11.70E+3	15
22	14.94E+6	15		49	178.68E+3	15		76	10.80E+3	15
23	13.95E+6	15		50	159.48E+3	15		77	9.97E+3	15
24	13.06E+6	15		51	142.67E+3	15		78	9.22E+3	15
25	12.26E+6	15		52	127.91E+3	15		79	8.53E+3	15
26	6.49E+6	15		53	114.91E+3	15		80	7.91E+3	15
27	5.87E+6	15		54	103.44E+3	15		81	7.33E+3	15
28	5.32E+6	15		55	93.30E+3	15		82	6.80E+3	15
29	3.42E+6	15		56	84.30E+3	15		83	6.32E+3	15
30	2.82E+6	15		57	76.31E+3	15		84	5.88E+3	15
31	2.35E+6	15		58	69.20E+3	15		85	5.47E+3	15
32	1.96E+6	15		59	62.86E+3	15		86	5.09E+3	15
33	1.65E+6	15		60	57.19E+3	15		87	4.75E+3	15
34	1.40E+6	15		61	52.11E+3	15		88	4.43E+3	15
35	1.19E+6	15		62	37.22E+3	15		89	4.13E+3	15
36	1.01E+6	15		63	33.77E+3	15		90	3.86E+3	15

25°C

%RH	OHMS	°C		%RH	OHMS	°C		%RH	OHMS	°C
10	24.76E+6	25		37	312.28E+3	25		64	14.36E+3	25
11	21.68E+6	25		38	272.42E+3	25		65	13.14E+3	25
12	19.19E+6	25		39	238.49E+3	25		66	12.04E+3	25
13	17.16E+6	25		40	209.50E+3	25		67	11.05E+3	25
14	15.47E+6	25		41	184.61E+3	25		68	10.15E+3	25
15	14.05E+6	25		42	163.18E+3	25		69	9.33E+3	25
16	12.84E+6	25		43	144.66E+3	25		70	8.59E+3	25
17	9.05E+6	25		44	128.60E+3	25		71	7.92E+3	25
18	7.84E+6	25		45	114.62E+3	25		72	7.31E+3	25
19	6.84E+6	25		46	102.42E+3	25		73	6.76E+3	25
20	6.00E+6	25		47	91.74E+3	25		74	6.25E+3	25
21	5.31E+6	25		48	82.37E+3	25		75	5.79E+3	25
22	4.47E+6	25		49	74.11E+3	25		76	5.36E+3	25
23	3.56E+6	25		50	66.83E+3	25		77	4.51E+3	25
24	2.86E+6	25		51	60.39E+3	25		78	4.17E+3	25
25	2.32E+6	25		52	54.67E+3	25		79	3.86E+3	25
26	1.90E+6	25		53	42.35E+3	25		80	3.57E+3	25
27	1.57E+6	25		54	38.04E+3	25		81	3.31E+3	25
28	1.30E+6	25		55	34.24E+3	25		82	3.07E+3	25
29	1.09E+6	25		56	30.88E+3	25		83	2.85E+3	25
30	913.89E+3	25		57	27.90E+3	25		84	2.65E+3	25
31	772.65E+3	25		58	25.26E+3	25		85	2.47E+3	25
32	656.72E+3	25		59	22.90E+3	25		86	2.30E+3	25
33	560.99E+3	25		60	20.80E+3	25		87	2.14E+3	25
34	481.47E+3	25		61	18.92E+3	25		88	1.99E+3	25
35	415.06E+3	25		62	17.23E+3	25		89	1.86E+3	25
36	359.31E+3	25		63	15.72E+3	25		90	1.74E+3	25

UPS-500 DATA CHARTS

35°C

% RH	OHMS	°C		% RH	OHMS	°C		% RH	OHMS	°C
10	12.66E+6	35		37	120.10E+3	35		64	7.06E+3	35
11	11.99E+6	35		38	106.10E+3	35		65	6.49E+3	35
12	9.75E+6	35		39	94.03E+3	35		66	5.98E+3	35
13	8.05E+6	35		40	83.59E+3	35		67	5.51E+3	35
14	6.75E+6	35		41	74.53E+3	35		68	5.09E+3	35
15	5.73E+6	35		42	66.63E+3	35		69	4.92E+3	35
16	5.91E+6	35		43	59.73E+3	35		70	4.53E+3	35
17	4.46E+6	35		44	53.68E+3	35		71	4.17E+3	35
18	3.42E+6	35		45	47.46E+3	35		72	3.85E+3	35
19	2.66E+6	35		46	42.14E+3	35		73	3.56E+3	35
20	2.10E+6	35		47	37.51E+3	35		74	3.29E+3	35
21	1.67E+6	35		48	33.47E+3	35		75	3.05E+3	35
22	1.35E+6	35		49	29.94E+3	35		76	2.83E+3	35
23	1.09E+6	35		50	26.84E+3	35		77	2.62E+3	35
24	898.02E+3	35		51	24.12E+3	35		78	2.43E+3	35
25	742.82E+3	35		52	21.71E+3	35		79	2.26E+3	35
26	619.04E+3	35		53	19.59E+3	35		80	2.11E+3	35
27	519.44E+3	35		54	17.70E+3	35		81	1.96E+3	35
28	438.66E+3	35		55	16.03E+3	35		82	1.83E+3	35
29	372.64E+3	35		56	14.54E+3	35		83	1.71E+3	35
30	318.32E+3	35		57	13.21E+3	35		84	1.59E+3	35
31	273.32E+3	35		58	12.03E+3	35		85	1.49E+3	35
32	235.82E+3	35		59	10.97E+3	35		86	1.39E+3	35
33	204.40E+3	35		60	10.01E+3	35		87	1.30E+3	35
34	177.92E+3	35		61	9.16E+3	35		88	1.22E+3	35
35	155.49E+3	35		62	8.39E+3	35		89	1.14E+3	35
36	136.41E+3	35		63	7.69E+3	35		90	1.07E+3	35

45°C

% RH	OHMS	°C		% RH	OHMS	°C		% RH	OHMS	°C
10	6.89E+6	45		37	49.05E+3	45		64	3.63E+3	45
11	5.56E+6	45		38	43.84E+3	45		65	3.35E+3	45
12	4.58E+6	45		39	39.31E+3	45		66	3.10E+3	45
13	3.99E+6	45		40	35.34E+3	45		67	2.87E+3	45
14	2.92E+6	45		41	35.26E+3	45		68	2.66E+3	45
15	2.19E+6	45		42	31.18E+3	45		69	2.47E+3	45
16	1.67E+6	45		43	27.65E+3	45		70	2.30E+3	45
17	1.29E+6	45		44	24.59E+3	45		71	2.14E+3	45
18	1.02E+6	45		45	21.92E+3	45		72	1.99E+3	45
19	808.70E+3	45		46	19.60E+3	45		73	1.85E+3	45
20	651.80E+3	45		47	17.56E+3	45		74	1.73E+3	45
21	530.89E+3	45		48	15.77E+3	45		75	1.62E+3	45
22	436.56E+3	45		49	14.19E+3	45		76	1.51E+3	45
23	362.13E+3	45		50	12.80E+3	45		77	1.41E+3	45
24	302.79E+3	45		51	11.57E+3	45		78	1.32E+3	45
25	255.03E+3	45		52	10.48E+3	45		79	1.24E+3	45
26	216.25E+3	45		53	9.51E+3	45		80	1.16E+3	45
27	184.52E+3	45		54	8.64E+3	45		81	1.09E+3	45
28	158.35E+3	45		55	7.87E+3	45		82	1.02E+3	45
29	136.63E+3	45		56	7.18E+3	45		83	963.08E+0	45
30	118.47E+3	45		57	6.56E+3	45		84	905.96E+0	45
31	103.21E+3	45		58	6.00E+3	45		85	852.84E+0	45
32	90.31E+3	45		59	5.50E+3	45		86	803.41E+0	45
33	79.35E+3	45		60	5.05E+3	45		87	757.37E+0	45
34	69.99E+3	45		61	4.64E+3	45		88	714.44E+0	45
35	61.96E+3	45		62	4.27E+3	45		89	674.40E+0	45
36	55.04E+3	45		63	3.93E+3	45		90	637.01E+0	45

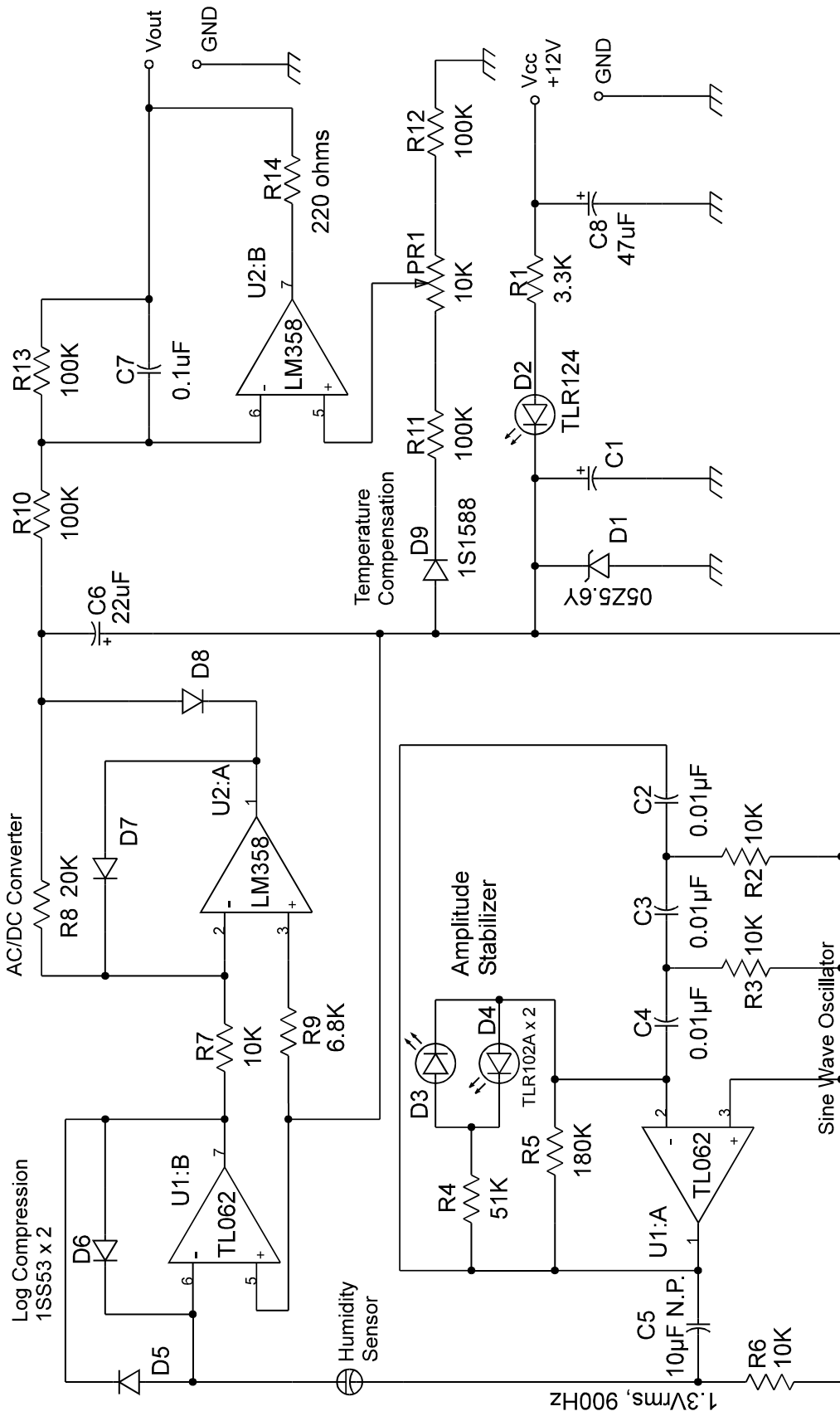

FUNCTIONAL DESCRIPTION OF EXAMPLE HUMIDITY MEASURING CIRCUIT

U1:A generates a sine wave of 900Hz , 1.3V rms . D3 and D4 use the forward voltage of the LED to stabilize the amplitude. U1:B uses the forward voltage-current characteristics of the silicon diode to produce a logarithmic signal. The current change resulting from the impedance change of the sensor is compressed logarithmically and yields a voltage. U1 needs to be an FET input type, since the impedance of the sensor exceeds 100 megohms at low humidity. The impedance of the sensor is affected by both humidity and temperature. Another method of temperature compensation is to use a microprocessor to run the sensor's equation.