



ohmic instruments co.

508 August St. Easton, MD 21601

Voice: (410) 820-5111

Fax: (410) 822-9633

www.ohmicinstruments.com

DIGITAL SAFETY INSPECTOR
Model SI-100ND

OWNER'S MANUAL

© Ohmic Instruments Company
2006

All rights reserved. This manual may not be reproduced in complete form without written permission of Ohmic Instruments Company. Test forms may be copied as required by the original purchaser of the instrument. Information contained in this manual is believed to be accurate and reliable; however, no responsibility is assumed by Ohmic Instruments Company for its use. Ohmic reserves the right to supply its instruments with design changes and/or component substitutions that may not be documented in this manual.

INTRODUCTION

Ohmic Company's Digital Safety Inspector, Model SI-100ND, is designed to check rapidly the electrical safety of medical and other line-operated equipment having no patient leads. It can also be used to check voltage differentials and grounding in patient areas.

Leakage currents to 1999 μ A and grounding resistances to 19.99 ohms are displayed on a highly visible 3½ digit LED readout. The Equipment Under Test (EUT) is simply plugged into one of two front panel test receptacles which are used for either the Grounding Resistance/Poor Insulation or Leakage Current test. The Grounding Resistance test measures the resistance between the ground prong on the EUT's AC plug and the point on the EUT's chassis where the green wire is connected. The Poor Insulation LED indicates faulty insulation of the EUT's hot or neutral lines from ground. The Leakage Current test can be conducted in either Normal or Reverse polarity using a heavy-duty toggle switch on the SI-100ND. An included dual-function test probe allows the user to make external leakage, differential voltage and resistance tests on electrical equipment that cannot be plugged into the SI-100ND's test receptacle.

PANEL CONTROLS

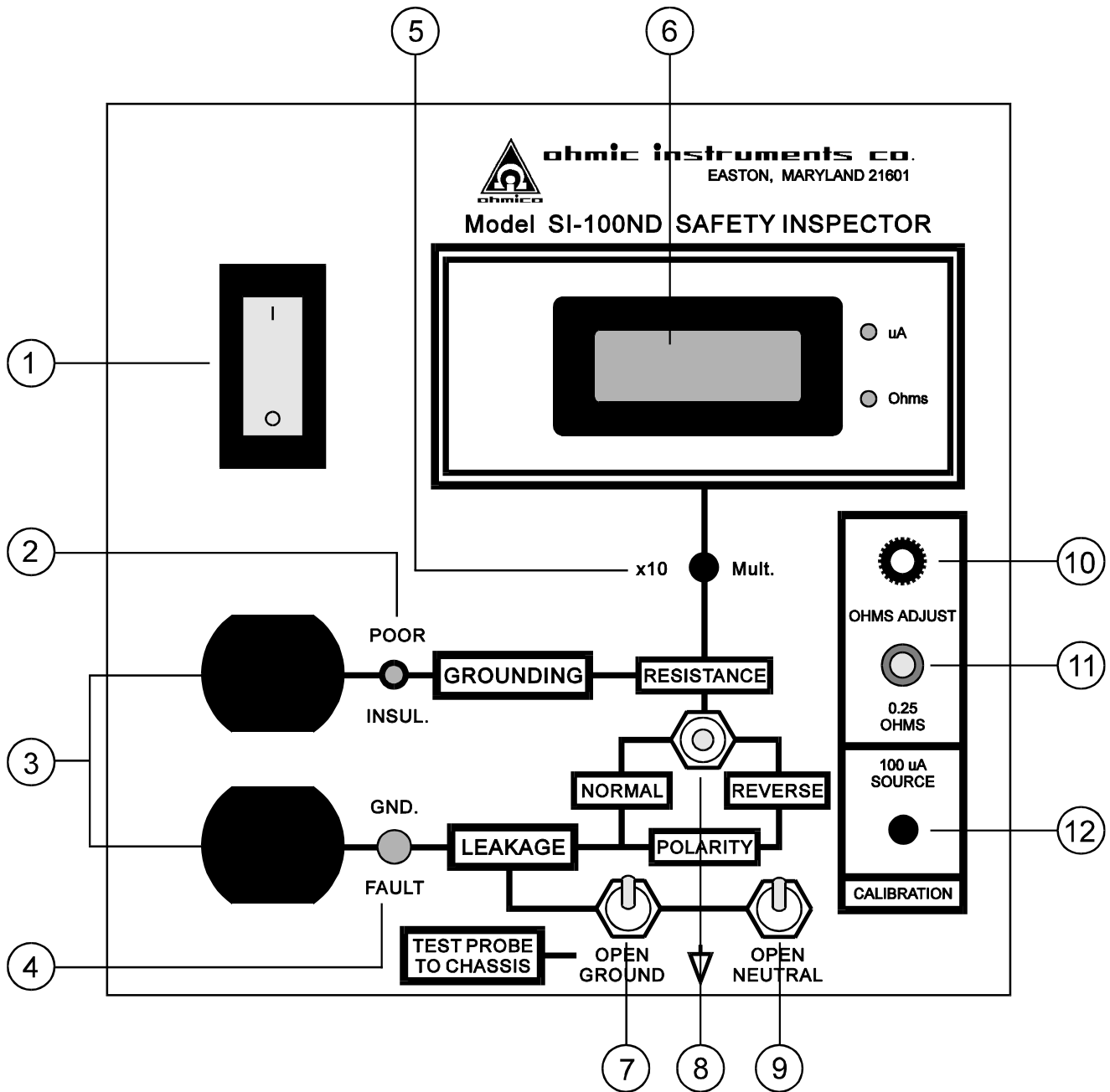

1) *Two-Pole Magnetic Breaker.* Applies power to test receptacles and measuring circuit.

2) *Poor Insulation LED.* Lights up if the Equipment Under Test's (EUT's) Hot/Neutral insulation from ground is below 1 Megohm.

3) *Hospital-Grade Duplex Test Receptacle:* GROUNDING: For Grounding Resistance test (non-energized receptacle). LEAKAGE: For Leakage Current test (energized receptacle).

4) *Ground Fault Light.* Lights up if the probe tip or the ground slot of the Leakage receptacle comes in contact with a hot AC line.

- 5) *x10 Multiplier*. When depressed, increases the full-scale range of resistance or leakage readings by a factor of 10, shifting the decimal point one place to the right.
- 6) *Digital Display*. 3½ digit LED display with two separate LED range indicators for μA and Ohms.
- 7) *Open Ground Switch*. This normally-closed switch, when depressed, will disconnect the Leakage test receptacle Ground from the grounding conductor.
- 8) *Selector Switch*. Selects Normal or Reverse Leakage polarities, or Resistance test in the mid-position.
- 9) *Open Neutral Switch*. This normally-closed switch, when depressed, will disconnect the Leakage test receptacle Neutral from the neutral conductor.
- 10) *Ohms Adjust*. Adjusts the accuracy of the Resistance measuring circuit.
- 11) *0.25 Ohm Test*. This jack is connected to an internal calibration standard to assist in adjusting the Resistance measuring circuit.
- 12) *100 μA Source*. Checks functionality of Leakage measuring circuit by injecting 100 μA DC (this works only if the Selector Switch is in Normal or Reverse position).

The SI-100ND Safety Inspector also includes:

- **Test Probe**. This removeable coiled-cord probe enables leakage current and differential voltage tests. When the pushbutton on the probe is pushed, grounding resistance tests can be made.
- **1/4 Amp Fuse**. This protects the power supply of the unit.
- **1/16 Amp Fuse**. This protects the Resistance measuring circuit.

PLEASE NOTE: Only fast-blow fuses, of the correct value, should be used in the SI-100ND. The use of slow-blow and/or higher-value fuses in this unit can affect the accuracy of the Resistance measuring circuit, expose the unit's circuitry to a greater risk of damage, and void the warranty.

USING THE SAFETY INSPECTOR

CAUTION: *Do not use the Safety Inspector on any equipment that has a direct electrical connection to a patient's heart. The DC test current used to measure resistance may cause electrical shock.*

1. **RESISTANCE TESTS** Use Box 1 of the supplied test form, TF-24, to record readings (the test form plus a sample form can be found in the back of this manual).

- a) Plug the SI-100ND into a properly polarized and grounded 120V AC outlet and switch it on.
- b) Place the Selector switch in Resistance position and insert the Test Probe into the 0.25 Ohm Test jack. Depress the button on the probe and turn the Ohms Adjust knob until the display indicates 0.25 ohms.
- c) Plug the Equipment Under Test (EUT) into the Grounding receptacle of the SI-100ND.
- d) Touch the Test Probe to metal surfaces of the EUT (with the button on the Probe depressed), preferably close to the point where the green wire of the line cord is connected to the EUT. Flex the line cord at the plug and the chassis to check for intermittent connections. A fluctuation in the reading could be caused by contact resistance or a corroded connection. Record the reading on the test form (NFPA 76B calls out a 0.15 ohm maximum grounding resistance from the ground blade of the EUT to the point where the green wire is connected to the metal case. At other points of exposed metal surfaces of the EUT, resistance values may be higher).
- e) Turn on the power switch of the EUT. The Poor Insulation LED on the SI-100ND will come on if the combined hot and neutral to ground resistance of the EUT is below 1 megohm. This test will detect gross equipment insulation resistance faults due to cracked or deteriorated wiring insulation, dampness in equipment, or grounded neutral. Record the result on the test form.

NOTE: Due to the highly sensitive nature of the measurement circuitry, some minor fluctuations of the display may occur when no measurements are being made. This is due to electromagnetic interference from the ambient surroundings. In most instances this will not affect the performance of the SI-100ND.

USING THE SAFETY INSPECTOR

2. **LEAKAGE TESTS** Use Box 2 of the supplied test form to record readings.

- a) Place the Selector switch in either Normal or Reverse position.
- b) Depress the 100 μ A Source pushbutton. This should cause the display to read 100 μ A. *Note: The 100 μ A Source pushbutton will work correctly only if the Selector switch is in Normal or Reverse position.*
- c) Plug the EUT into the Leakage receptacle of the SI-100ND.
- d) Place the Selector switch in Normal position and turn on the power switch of the EUT. Record the reading on the test form.
- e) Turn off the power switch of the EUT. Record the leakage reading of the line cord (usually about 1 μ A per foot) on the test form.
- f) With the power switch of the EUT still off, place the SI-100ND's Selector switch in Reverse position. Record the leakage reading of the line cord on the test form.
- g) Turn on the power switch of the EUT. Record the reading on the test form.

3. **TESTING THE ELECTRICAL ENVIRONMENT** Use Box 3 of the supplied test form to record readings.

- a) Disconnect the EUT from the Safety Inspector.
- b) Place the Selector switch in the Resistance position.
- c) Touch the probe to exposed metal surfaces in the patient vicinity, and depress the button on the probe. Readings should be under 0.5 ohm.
- d) Touch the probe to ground slots of receptacles near the one the SI-100ND is plugged into, and depress the button on the probe. Readings should be under 0.15 ohm.
- e) Touch the probe to metal surfaces and to ground slots of receptacles in patient areas. Do not depress the button on the probe.
- f) Record the readings on the test form. The x10 Multiplier button can be used if necessary to extend the measurement range.

THE OPEN GROUND AND OPEN NEUTRAL SWITCHES

At the request of several hospitals these switches were added to the Safety Inspector.

The Open Ground Switch is used in the Leakage Current test to simulate a common fault condition in line cords and receptacles (this test is specified in AAMI ESI-1985, Par. 4.3.1.1). Depressing this switch will disconnect the Leakage receptacle on the SI-100ND from the grounding conductor.

The Open Neutral Switch disconnects the Leakage receptacle on the SI-100ND from the Neutral conductor. AAMI does not recommend this test because it would involve a double fault condition and the Equipment Under Test (EUT) would not operate in this mode. Readings are taken in the Leakage Current test mode, Normal polarity, while pressing the Open Neutral switch.

RECALIBRATION

For optimal performance Ohmic recommends that the SI-100ND be returned to Ohmic's facility in Easton, Maryland annually for recalibration. A nominal fee will be charged and a calibration certificate will be returned with the unit. Due to the complexity of the circuit, user calibration is not recommended.

SPECIFICATIONS

LEAKAGE CURRENT TEST

RANGES: 0 to 199.9 μ A (x1), DC or RMS
0 to 1999 μ A (x10), DC or RMS
RESOLUTION: 0.1 μ A (x1)
1 μ A (x10)
ACCURACY: \pm 3%
INPUT IMPEDANCE: 1000 Ohms (1 Kilohm), \pm 2%
FREQUENCY RESPONSE: DC to 1000Hz flat, -20db/decade above 1Khz
CALIBRATION TEST: 100 μ A, pushbutton selected

GROUNDING RESISTANCE TEST

RANGES: 0 to 1.999 Ohms (x1)
0 to 19.99 Ohms (x10)
RESOLUTION: 0.001 Ohm (x1)
0.01 Ohm (x10)
ACCURACY: \pm 5%
TEST CURRENT: 30mA
CIRCUIT PROTECTION: 1/16A, 250V Fast-acting fuse
CALIBRATION TEST: Internal 0.25 Ohm Resistor

POOR INSULATION TEST

INDICATOR: Light-Emitting Diode (LED)
POOR INSULATION LEVEL: Below 1 Megohm, Ground to Hot/Neutral
TEST VOLTAGE: 100 Volts DC, \pm 5%
TEST CURRENT: 250 μ A

DIFFERENTIAL VOLTAGE TEST

RANGES: 0 to 199.9 millivolts (mV) (x1), DC or RMS
0 to 1.99 volts (x10), DC or RMS
RESOLUTION: 0.1mV (x1)
1mV (x10)
LOADING RESISTANCE: 1000 Ohms

ELECTRICAL/MECHANICAL

TEST RECEPTACLES: Heavy-Duty NEMA Duplex, Hospital Grade; One Half Non-energized for Grounding/Insulation Test; One Half Energized for Leakage Tests
LOAD CURRENT: 10 Amperes, Max.
OVERLOAD PROTECTION: 15 Ampere Two-pole Circuit Breaker
DISPLAY: 3½ Digit LED, 0.5" Character Height
UNITS DISPLAY: Two LED Indicators, μ A and Ohms
TEST SWITCHES: Normal/Reverse Polarity and Resistance Toggle Switch; Momentary Open Neutral and Open Ground Toggle Switches; x10 Pushbutton; 100 μ A Calibration Test Switch
EXTERNAL TEST PROBE: Removable, Hand-held, Coiled-cord probe with Pushbutton for Resistance Test
STANDBY POWER: 120 Volts AC, 60Hz, 5 Watts
POWER CORD: 6-foot 14/3, Type SJ
CASE DIMENSIONS: 4" High x 8" Wide x 8" Long with High-Impact Carrying Case

WARRANTY

Notwithstanding any provision of any agreement the following warranty is exclusive.

Ohmic Instruments COMPANY warrants each instrument it manufactures to be free from defects in material and workmanship under normal use and service for the period of 1-year from date of purchase. This warranty extends only to the original purchaser. This warranty shall not apply to fuses or any product or parts which have been subjected to misuse, neglect, accident, or abnormal conditions of operation.

In the event of failure of a product covered by this warranty, Ohmic Instruments Co. will repair and recalibrate an instrument returned within 1 year of the original purchase: provided the warrantor's examination discloses to its satisfaction that the product was defective. The warrantor may, at its option, replace the product in lieu of repair. With regard to any instrument returned within 1 year of the original purchase, said repairs or replacement will be made without charge. If the failure has been caused by misuse, neglect, accident, or abnormal conditions of operations, repairs will be billed at a nominal cost. In such case, an estimate will be submitted before work is started, if requested.

THE FOREGOING WARRANTY IS IN LIEU OF ALL OTHER WARRANTIES, EXPRESS OR IMPLIED, INCLUDING BUT NOT LIMITED TO ANY IMPLIED WARRANTY OF MERCHANTABILITY, FITNESS, OR ADEQUACY FOR ANY PARTICULAR PURPOSE OR USE. OHMIC INSTRUMENTS COMPANY SHALL NOT BE LIABLE FOR ANY SPECIAL, INCIDENTAL, OR CONSEQUENTIAL DAMAGES, WHETHER IN CONTRACT, TORT, OR OTHERWISE.

If any failure occurs, the following steps should be taken:

1. Notify Ohmic Instruments Co. giving full details of the difficulty, and include the model, type, and serial numbers (where applicable). On receipt of this information, service data, or shipping instructions will be forwarded to you.

2. On receipt of shipping instructions, forward the instrument, transportation prepaid. Repairs will be made and the instrument returned, transportation prepaid.

SHIPPING TO MANUFACTURER FOR REPAIR OR ADJUSTMENT

All shipments of Ohmic Instruments Co. instruments should be made via United Parcel Service or "Best Way" prepaid. The instrument should be shipped in the original packing carton, or if it is not available, use any suitable container that is rigid and of adequate size. If a substitute container is used, the instrument should be wrapped in packing material and surrounded with at least four inches of excelsior or similar shock absorbing material.

CLAIM FOR DAMAGE IN SHIPMENT TO ORIGINAL PURCHASER

The instrument should be thoroughly inspected immediately upon delivery to purchaser. All material in the shipping container should be checked against the enclosed packing list. The manufacturer will not be responsible for shortages against the packing sheet unless notified immediately. If the instrument is damaged in any way, a claim should be filed with the carrier immediately. (To obtain a quotation to repair shipment damage, contact Ohmic Instruments.) Final claim and negotiations with the carrier must be completed by the customer.

Ohmic Instruments Company will be pleased to answer all application or use questions, which will enhance your use of this instrument. Please address your requests or correspondence to: Ohmic Instruments Company, 508 August St., Easton, Maryland 21601, ATTN: Technical Support; or call Ohmic Technical Support at 410-820-5111.

MEDICAL EQUIPMENT WITHOUT PATIENT LEADS USING: OHMIC SAFETY INSPECTOR, MODEL SI-100ND						
EQUIPMENT	Electric Bed					
LOCATION	Ward 2, East					
MFR.	ACC Co.					
CONTROL #	301					
MODEL #	SERIAL # 1009					
* MAXIMUM ALLOWABLE READINGS SUGGESTED BY NFPA, NEC, AAMI	TEST DATE	7/12/00	1/12/01			
	INITIALS	HBK	HBK			
	PHYSICAL INSPECTION (60Hz)	OK	OK			
1	RESISTANCE FROM PLUG, U-BLADE TO CASE	0.15 Ohm*	0.11 ohms			
	INSULATION: HOT/NEU. TO GND (>1M Ohm LED OFF)	1 Megohm	OK			
2	CASE TO GROUND LEAKAGE CURRENT	NORMAL POLARITY	POWER ON	100µA*	25.3µA	28.5µA
		REVERSE POLARITY	POWER OFF	100µA*	10.1µA	10.3µA
	LEAKAGE CURRENT or VOLTAGE GRADIENT BETWEEN RECEPTACLE GROUNDS AND METAL SURFACES	NORMAL POLARITY	POWER ON	100µA*	10.2µA	10.4µA
		REVERSE POLARITY	POWER OFF	100µA*	32.7µA	34.3µA
3	LEAKAGE CURRENT or VOLTAGE GRADIENT BETWEEN RECEPTACLE GROUNDS AND METAL SURFACES	O.R., C.C.U., I.C.U.	10µA*	Under	Under	
		GENERAL PATIENT AREA	10mV*	10µA	10µA	
				100µA*		
				100mV*		

MEDICAL EQUIPMENT WITHOUT PATIENT LEADS USING: OHMIC SAFETY INSPECTOR, MODEL SI-100ND

EQUIPMENT		MFR.	MODEL #							
LOCATION		CONTROL #		SERIAL #						
* MAXIMUM ALLOWABLE READINGS SUGGESTED BY NFPA, NEC, AAMI	PHYSICAL INSPECTION (60Hz)	TEST DATE								
		INITIALS								
RESISTANCE FROM PLUG, U-BLADE, TO CASE		0.15 Ohm*								
INSULATION: HOT/NEU. TO GND. (>1Mohm LED OFF)		1 Megohm								
2	CASE TO GROUND LEAKAGE CURRENT	NORMAL POLARITY	POWER ON	100µA*						
			POWER OFF	100µA*						
		REVERSE POLARITY	POWER ON	100µA*						
			POWER OFF	100µA*						
3	LEAKAGE CURRENT or VOLTAGE GRADIENT BETWEEN RECEPTACLE GROUNDS AND METAL SURFACES	O.R., C.C.U., I.C.U.		10µA*						
		GENERAL PATIENT AREA		100µA*						
		100mV*								