

WARRANTY

Notwithstanding any provision of any agreement the following warranty is exclusive.

Ohmic Instruments Company warrants each instrument it manufactures to be free from defects in material and workmanship under normal use and service for the period of 1-year from date of purchase (pressure sensors on the PPM units are warranted for 90 days only). This warranty extends only to the original purchaser. This warranty shall not apply to fuses or any product or parts which have been subjected to misuse, neglect, accident, or abnormal conditions of operation.

In the event of failure of a product covered by this warranty, Ohmic Instruments Co. will repair and recalibrate an instrument returned within 1 year of the original purchase: provided the warrantor's examination discloses to its satisfaction that the product was defective. The warrantor may, at its option, replace the product in lieu of repair. With regard to any instrument returned within 1 year of the original purchase, said repairs or replacement will be made without charge. If the failure has been caused by misuse, neglect, accident, or abnormal conditions of operations, repairs will be billed at a nominal cost. In such case, an estimate will be submitted before work is started, if requested.

THE FOREGOING WARRANTY IS IN LIEU OF ALL OTHER WARRANTIES, EXPRESSED OR IMPLIED, INCLUDING BUT NOT LIMITED TO ANY IMPLIED WARRANTY OF MERCHANTABILITY, FITNESS, OR ADEQUACY FOR ANY PARTICULAR PURPOSE OR USE. OHMIC INSTRUMENTS COMPANY SHALL NOT BE LIABLE FOR ANY SPECIAL, INCIDENTAL, OR CONSEQUENTIAL DAMAGES, WHETHER IN CONTRACT, TORT, OR OTHERWISE.

If any failure occurs, the following steps should be taken:

1. Notify Ohmic Instruments Co. giving full details of the difficulty, and include the model, type, and serial numbers (where applicable). On receipt of this information, service data, or shipping instructions will be forwarded to you.

2. On receipt of shipping instructions, forward the instrument, transportation prepaid. Repairs will be made and the instrument returned, transportation prepaid.

SHIPPING TO MANUFACTURER FOR REPAIR OR ADJUSTMENT

All shipments of Ohmic Instruments Co. instruments should be made via United Parcel Service or "Best Way" prepaid. The instrument should be shipped in the original packing carton, or if it is not available, use any suitable container that is rigid and of adequate size. If a substitute container is used, the instrument should be wrapped in packing material and surrounded with at least four inches of excelsior or similar shock absorbing material.

CLAIM FOR DAMAGE IN SHIPMENT TO ORIGINAL PURCHASER

The instrument should be thoroughly inspected immediately upon delivery to purchaser. All material in the shipping container should be checked against the enclosed packing list. The manufacturer will not be responsible for shortages against the packing sheet unless notified immediately. If the instrument is damaged in any way, a claim should be filed with the carrier immediately. (To obtain a quotation to repair shipment damage, contact Ohmic Instruments.) Final claim and negotiations with the carrier must be completed by the customer.

Ohmic Instruments Company will be pleased to answer all application or use questions, which will enhance your use of this instrument. Please address your requests or correspondence to: Ohmic Instruments Company, 508 August St., Easton, Maryland 21601, ATTN: Technical Support. Or call Ohmic Technical Support at 410-820-5111.

All rights reserved. This manual may not be reproduced in full or in part without written permission of Ohmic Instruments Company. Information contained within this manual is believed to be accurate and reliable. However, Ohmic Instruments Company assumes no liability for its use. Ohmic Instruments Company reserves the right to supply its instruments with design changes and/or component substitutions that may not be documented in this manual.



ohmic instruments co.

508 August Street Easton, MD 21601

www.ohmicinstruments.com

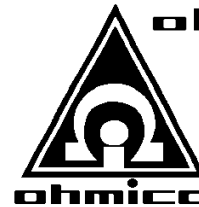

ohmic instruments co.

508 August Street Easton, MD 21601

www.ohmicinstruments.com

Voice (410) 820-5111

Fax (410) 822-9633

PRECISION PRESSURE MONITOR Models PPM-1, -5, -15, -30, -100

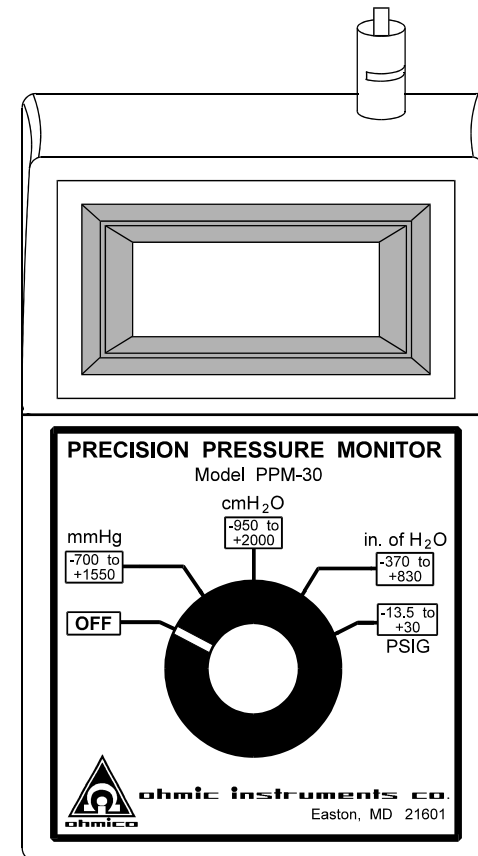

OPERATING NOTES

© Ohmic Instruments Company
2006

All rights reserved. This manual may not be reproduced in complete form without written permission of Ohmic Instruments Company. Individual pages may be copied as needed by the original purchaser. Information contained in this manual is believed to be accurate and reliable, however, no responsibility is assumed by Ohmic Instruments Company for its use. Ohmic Company reserves the right to supply its instruments with design changes and/or component substitutions that may not be documented in this manual.

PRESSURE UNIT CONVERSIONS

To Obtain	Multiply	By
mmHg	cmH ₂ O	0.7355
mmHg	in.H ₂ O	1.868
mmHg	psi	51.715
cmH ₂ O	mmHg	1.3595
cmH ₂ O	in.H ₂ O	2.54
cmH ₂ O	psi	70.308
in.H ₂ O	mmHg	0.53525
in.H ₂ O	cmH ₂ O	0.3937
in.H ₂ O	psi	27.680
psi	mmHg	0.01934
psi	cmH ₂ O	0.01422
psi	in.H ₂ O	0.3613

APPLICATION NOTES

PRESSURE MEASUREMENTS

Gage - Differential - Absolute

Gage This pressure measurement uses the sea-level atmospheric pressure as its zero reference. It is the most common method of expressing pressures in the health care field. A reading of one (1) atmosphere at sea level gives the zero pressure reference. Pressures greater than one atmosphere are positive and pressures less than one atmosphere are negative. The most negative gage pressure is a perfect vacuum. Gage pressure units are generally suffixed with "g" or specified as "gage". The table below shows how vacuum, the one atmosphere reference, and a pressure of two atmospheres are related on the gage scale.

	psig	mmHg gage	cmH₂O gage	in. H₂O gage
Vacuum	-14.7	-760	-1033.5	-406.9
1 Atmosphere	0	0	0	0
2 Atmospheres	+14.7	+760	+1033.5	+406.9

Differential This method of expressing pressure is used to describe the difference in pressure between two sources, called input ports. One port is connected to the higher pressure and the other port is connected to the lower pressure. The high pressure is expressed as a positive pressure with respect to the low pressure. Differential pressure units are generally suffixed with "d" or specified as "differential". (Example: 2.5 psid = 129 mmHg differential)

Absolute This is a pressure that is measured by using vacuum as the zero reference. A perfect vacuum has a zero absolute pressure and other positive pressures are referenced to it as there is no negative pressure on the absolute pressure scale. Absolute pressure units are generally suffixed with an "a" or specified as "absolute". The table below shows how the vacuum reference and two atmospheres are related on the absolute scale.

	psia	mmHg absolute	cmH₂O absolute	in. H₂O absolute
Vacuum	0	0	0	0
1 Atmosphere	+14.7	+760	+1033.5	+406.9
2 Atmospheres	+29.4	+1520	+2067	+813.8

Contents

Introduction 5

Operating Controls..... 6

How to Use the PPM Precision Pressure Monitor 7

How to Zero the PPM Precision Pressure Monitor 8

Special Notice for PPM-100 Only 8

Specifications..... 9

Application Notes..... 10

Pressure Unit Conversions 11

Warranty 12

SPECIFICATIONS

Electrical

Pressure Sensor: Piezoresistive type
Media Compatibility: Most non-corrosive liquids and gases; must be generally compatible with silicon gel, RTV, plastic, aluminum and glass. Switching between liquids and gases is not recommended.

Pressure Ranges:

Model	mmHg	cmH₂O	in.H₂O	PSIG
PPM-1	-50.0 to +50.0	-70.0 to +70.0	-28.0 to +28.0	-1.000 to +1.000
PPM-5	-250 to +250	-350 to +350	-135.0 to +135.0	-5.00 to +5.00
PPM-15	-700 to +75	-950 to +1050	-370 to +15	-13.50 to +15.00
PPM-30	-700 to +1550	-950 to +1999	-370 to +830	-13.50 to +19.99
PPM-100	-700 to +1999	-950 to +1999	-370 to +1999	-13.5 to +100.0

Accuracy: $\pm 1.0\%$ of full scale

Display: 3½ Digit Liquid Crystal Display (LCD) with Low Battery Indicator

Operating Temperature: Temp. Compensated over +32°F to +150°F

Pressure Input Fitting: Male Luer Lock (for 5/32" I.D., 9/32" O.D.Tubing)

Maximum Pressure: PPM-1: 1 PSI

PPM-5: 5 PSI

PPM-15: 15 PSI

PPM-30: 30 PSI

PPM-100: 100PSI

Power: 9 Volt Rechargeable Battery

Mechanical

Size: 3.5" wide x 5.6" long x 2" high

Case Description: High Impact ABS Plastic Case

Weight: 12 Ounces

5. If BAT is indicated in the upper left corner of the display, the battery is weak and should be recharged.

6. Always set the range selector switch to the OFF position when the PPM is not in use. This will prolong the charge of the battery which is normally 30 to 40 hours of continuous use.

HOW TO ZERO THE PPM PRECISION PRESSURE MONITOR

1. Remove any connection to the pressure inlet of the pressure monitor. The inlet should be open to the atmosphere.
2. Set the range selector switch on mm Hg.
3. The access hole to the Zero Adjustment is located on the left side of the instrument. Using a small screwdriver, turn this adjustment until the display indicates zero.

SPECIAL NOTICE FOR PPM-100 ONLY

Use caution to avoid excessive pressure over 120 psi since this could damage the sensor or tubing in the PPM. Use the appropriate luer lock fitting and properly rated tubing and clamps when taking measurements.

For high pressure applications, smaller 1/16" or 1/8" I.D. tubing is suggested for safety purposes. Polyurethane and teflon tubing have stiff walls and are readily available.

The PPM is not intended to be permanently connected to a pressurized line. An hour or two on the line is acceptable as long as there are no sudden peak pressures above 120 psi.

INTRODUCTION

OHMIC Company's Precision Pressure Monitor (PPM) is a precision pressure monitoring instrument capable of measuring in any of four selectable pressure units; mm Hg, cm H₂O, in. of H₂O, and psig. This portable hand-held instrument uses a piezoresistive pressure transducer having a $\pm 1.0\%$ full scale accuracy and was designed for use in the medical environment to check the calibration on a variety of equipment, such as dialysis machines, I.V. pumps, suction devices, and pressure gauges. It can measure positive or negative pressure of gases or liquids in any of the four selectable units of measure (NOTE: Switching between liquids and gases is not recommended, as liquids usually remain in the internal tubing that feeds the transducer. Designating your PPM as gas-only or liquid-only should prevent problems). The standard PPM Series Precision Pressure Monitors that are available are the PPM-1, PPM-5, PPM-15, PPM-30 and PPM-100, which cover different full scale ranges using the same pressure measuring units.

The pressure to be measured is connected to the PPM through a male luer lock pressure fitting. A 3½-digit LCD display indicates the measured pressure with a resolution of ± 1 digit or ± 0.1 digit depending on the position of the range selection switch. The range selection switch also has a position to turn the instrument OFF. A zero adjustment is accessible through the side of the case to null any ambient atmospheric pressures which may cause measurement errors. The instrument is powered by a 9-volt rechargeable battery which will provide years of service and can be recharged with the included battery charger. When the battery is weak, the LCD display will indicate BAT in the upper left corner of the display window. This indicates the unit should be put on charge for about 8 hours for full operating power. The pressure measurements made with this instrument are fully temperature compensated over an operating temperature range of +32° to +150°F. All PPM Series Precision Pressure Monitors are fully guaranteed for 90 days on the pressure sensor and for one year on all other parts.

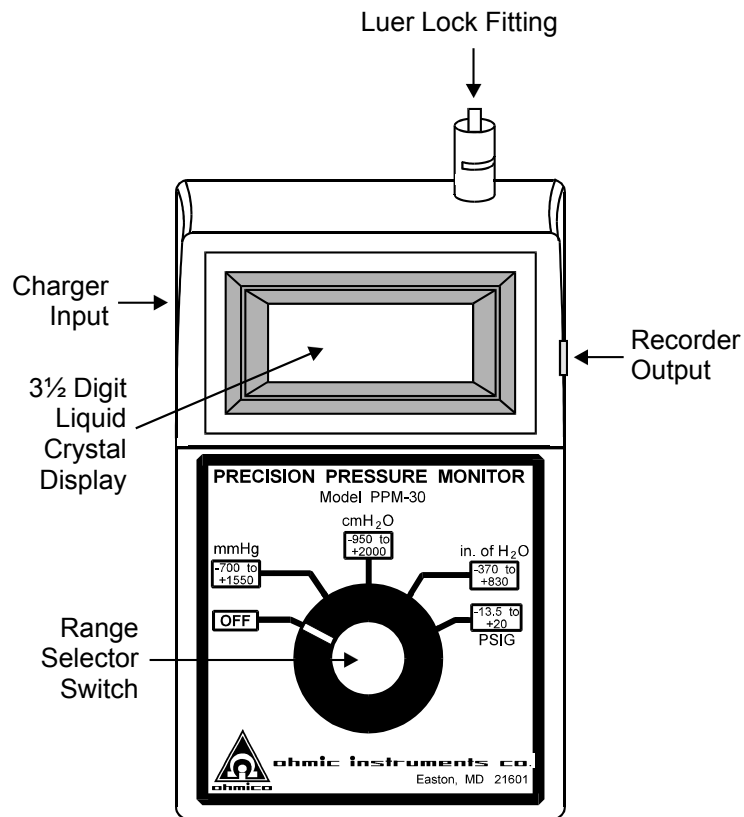

OPERATING CONTROLS

1. **LCD DISPLAY.** The liquid crystal digital display indicates the measured pressure value either in mm Hg, cm H₂O, in. of H₂O, or psig depending on the position of the RANGE SELECTION SWITCH. The display resolution is ± 1 unit on all ranges except psig which is ± 0.01 unit. If the rechargeable battery is too weak to adequately power the instrument, the display will show "BAT" in the upper left corner and the PPM should be put on charge for about 8 hours. If excessive pressure is applied to the instrument, the display will show an overrange indication as "1" in the most significant digit position.

2. **RANGE SELECTION SWITCH.** This is a five-position rotary switch used to select measurements in any of four pressure units; millimeters of mercury (mm Hg), centimeters of water (cm H₂O), inches of water (in. of H₂O), or pounds per square inch gage (psig). When the units selection is made, the instrument will also be turned ON. The full counterclockwise position of this switch will turn the unit OFF.

3. **ZERO ADJUSTMENT.** A small hole on the left side of the instrument allows access to a multi-turn trim potentiometer for adjusting the display reading to read zero when no pressure is applied (ambient atmospheric pressure). This allows all pressure measurements to be referenced to the prevailing barometric pressure. If another pressure is to be used as a reference, then this reference pressure must be applied to the instrument before and then nulled out using the ZERO Adjustment.

4. **LUER LOCK PRESSURE FITTING.** The applied pressure must be connected to this pressure fitting using 5/32" I.D. plastic or rubber tubing with an O.D. of about 9/32". This fitting has a central connection port with an outer collar which has internal threads to lock the tubing in place by simply pushing the tubing on the center port connection and twisting clockwise. Slots on the threaded collar allow inspection to assure the tubing is adequately locked into the fitting.

5. **CHARGER INPUT JACK.** On the left side of the PPM is a power jack for connecting the charger unit to recharge the internal battery. The charger supplies +12 vdc to charge up the +9 volt rechargeable battery. **DO NOT USE OTHER CHARGERS WITH THIS INSTRUMENT SINCE INTERNAL DAMAGE MAY OCCUR.** In normal operation, a single charge should last for about 30 to 40 hours of continuous use.

6. **RECORDER OUTPUT JACK.** This is a 1/8" Mono phono jack provided for connecting a recording device or computer to the PPM for recording pressure readings. The DC output voltage is 0.1 millivolt per pressure unit for all pressure selections except psig which is 1 millivolt per psi.

HOW TO USE THE PPM PRECISION PRESSURE MONITOR

1. **Zero Check.** With no pressure applied to the Pressure Monitor (i.e., pressure inlet should be open to the atmosphere), set the range switch to mm Hg. The display should indicate zero. All other ranges should also read zero. If the reading is not zero, follow the instructions "How To Zero The PPM Precision Pressure Monitors".

2. Connect a length of 5/32-inch I.D. (9/32-inch O.D.) plastic or rubber tubing from the luer lock pressure fitting to the pressure source to be monitored.

3. Set the range switch to the desired pressure units.

4. If the display indicates "1", then the applied pressure is too high for the unit to measure. Pressures greater than twice the full scale range may cause permanent damage to the piezoresistive pressure sensor.