



ohmic instruments co.

508 August St. Easton, MD
21601

Voice: (410) 820-5111

Fax: (410) 822-9633

www.ohmicinstruments.com

HC-610
CAPACITIVE HYBRID RELATIVE HUMIDITY
SENSOR
APPLICATION NOTES

© 2006 Ohmic Instruments Company, Easton, MD

HC-610 PRECAUTIONS

CAUTION: IMPROPER HANDLING

- Do not remove the sensors from their original protective packaging until they are ready to be installed.
- Do not touch the sensor surface. Use latex finger cots. Handle sensor by package edges or leads.
- Do not allow objects to enter the cavity of the sensor element.

Failure to comply with these instructions may result in product damage.

WARNING: PERSONAL INJURY

- DO NOT USE these products as safety or emergency stop devices or in any other application where failure of the product could result in personal injury.

Failure to comply with these instructions could result in death or serious injury.

ELECTROSTATIC SENSITIVE DEVICE

ESD SENSITIVITY: CLASS 3

Protected to 15 KV max.

Shade from intense light

Temperature Limits: The operating temperature limit for the HC-610 is -40°F to $+185^{\circ}\text{F}$.

Chemical Vapors: The sensor's design provides better resistance to condensation and chemical vapors, such as organic solvents, chlorine, and ammonia. The sensor may be cleaned with isopropyl alcohol.

Installation of Sensors:

RECOMMENDED PCB MOUNTING: Mill-Max Socket Number 310-93-132-41-001 or similar. Sensors must be hand soldered. A heat sink should be used on the sensor legs when soldering to prevent excessive heat from reaching the pad on the sensor body. Carefully clean solder excess with a solder cleaner, but do not get any cleaner on the sensor itself. Hand soldering is recommended; however, if wave soldering is required, use no-clean flux. Limit the contact of the flux to the leads only. Recommended PC board wave soldering temperature is 250 to 260 $^{\circ}\text{C}$ (482 to 500 $^{\circ}\text{F}$).

CAUTION IMPROPER CLEANING

- Insert and solder the sensor after the PCB cleaning process.
- Clean sensor with isopropyl alcohol after soldering

Failure to comply with these instructions may result in product damage.

MOISTURE SEALING THE LEADS

If, in the presence of intermittent moisture or other contaminants, there is a possibility of galvanic paths between the leads, moisture seal the leads. Any nonconductive material such as silicone or Humiseal may be used.

Notes:

1. Extended exposure to $\geq 90\%$ RH causes a reversible shift of 3 % RH.
2. This sensor is light sensitive. For best results, shield the sensor from bright light.

DIMENSIONAL DRAWING: IN mm And () Thousands of an inch.

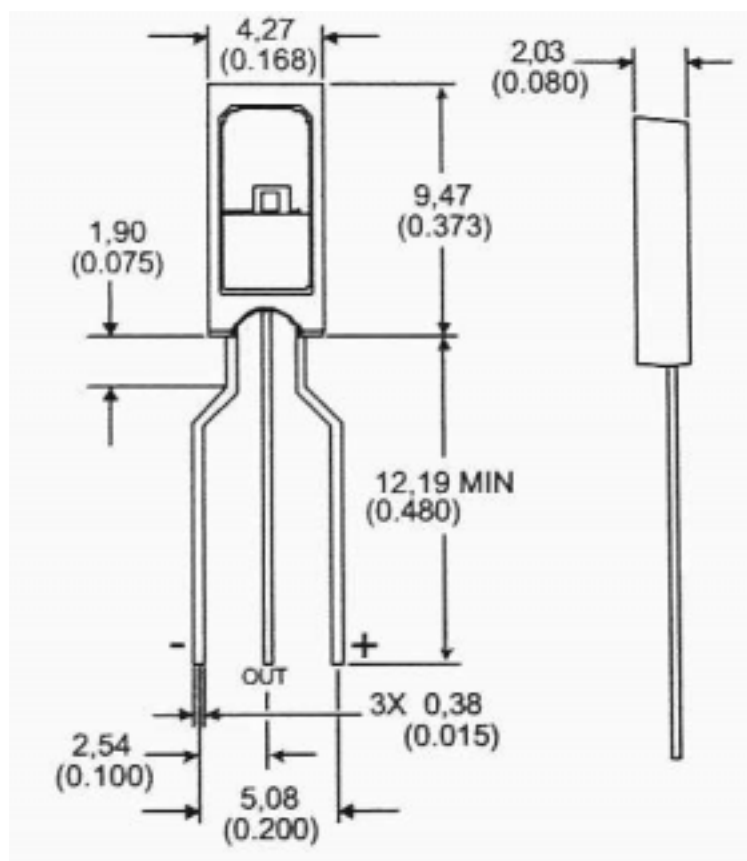

SPECIFICATIONS

Response Time	15 Seconds in slow moving air @ 25°C
Stability	± 1% RH Typ. at 50% RH In 5 Years
Total Accuracy	± 2% RH, 0-100% RH non-condensing @ 25°C
Interchangeability	± 5% RH
Operating Temperature	-40 to +85°C (-40 to +185°F)
Hysteresis	± 1.2% of Span Maximum
Linearity	± 0.5% RH Typical
Repeatability	± 0.5% RH
Voltage Supply (Vps)	4.0– 5.8 Vdc regulated
Voltage Output	$V_{out} = V_{ps} (0.0062 (\text{Sensor RH}) + . 16)$
RH Out	$\%RH = (((6.3 \times V_{out}) \div V_{ps}) - 1) \times 25.6$
Temperature Compensation	$\text{True RH} = \%RH \div (1.0546 - 0.00216T)$ where T= °C and %RH = Uncorrected % RH
Drive Capability	50µA typical, 20 µA minimum, 100 µA maximum
Turn-on Time	≤ 0.1 second
Current Requirement	200 µ A @5 Vdc Regulated
Handling/Installation	Electrostatic Sensitive. Protected to 15 KV Max. Shade from Intense Light

HC-610 RELATIVE HUMIDITY SENSOR CONNECTION AND EQUATION

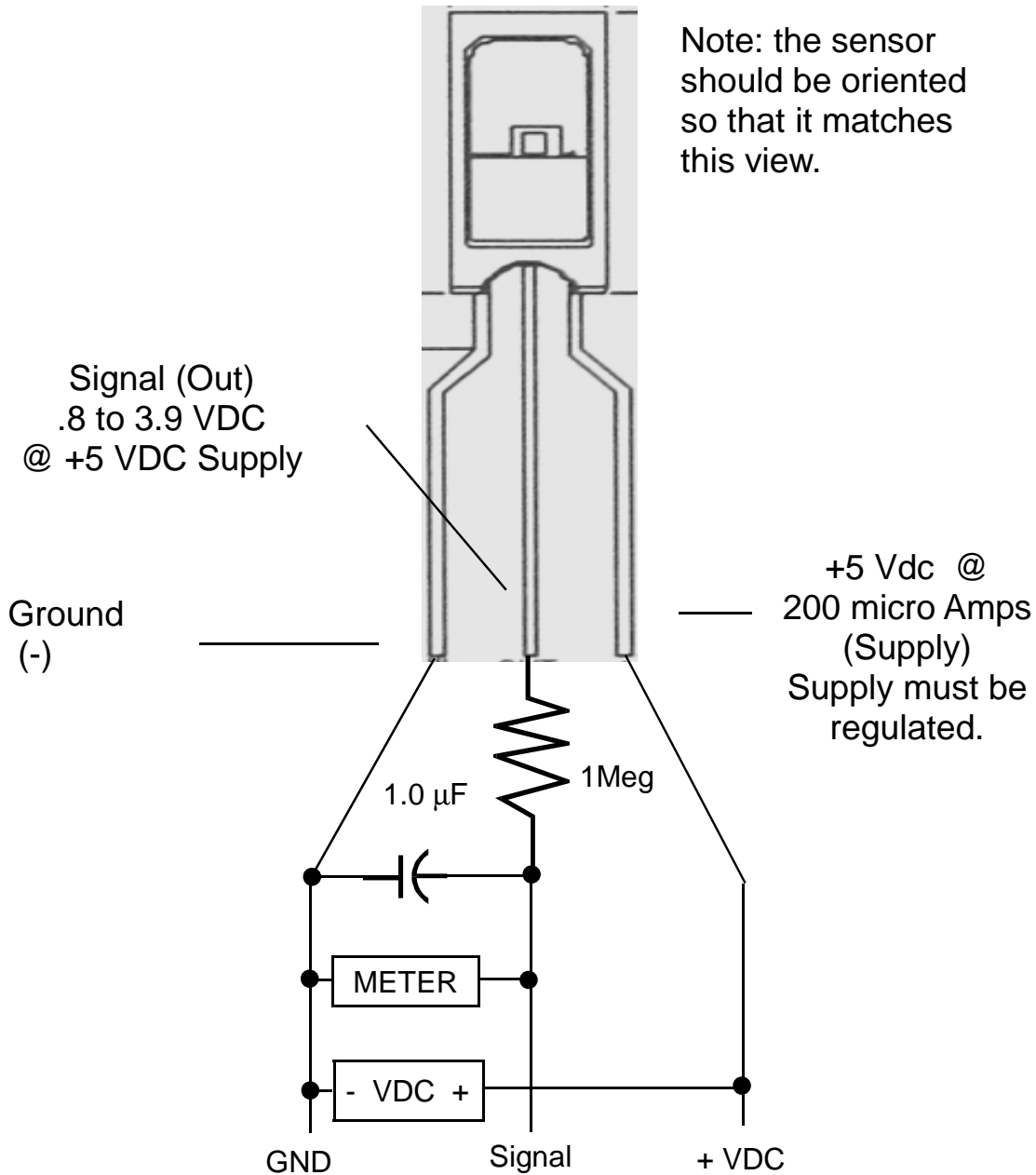

WARNING! Connecting the sensor wrong may damage the sensor. Double check your connections before applying power.

EQUATIONS:

Voltage Output: $V_{out} = V_{supply} (0.0062 (\text{Sensor RH}) + 0.16)$

%RH Out $\%RH = (((6.3 \times V_{out}) / V_{supply}) - 1) \times 25.6$

Sensors are temperature dependent. Apply the following temp. comp. equation to get true compensated %RH.

Temp Comp: $\text{True RH} = \text{Sensor RH} / (1.093 - 0.0012T)$, T in °F

Temp Comp: $\text{True RH} = \text{Sensor RH} / (1.0546 - 0.00216T)$, T in °C

HUMIDITY DISPLAY CIRCUIT

There are many ways to display the VDC Out vs. RH Data. The simplest is to connect a digital multimeter (DMM) and +5VDC regulated power supply to the sensor. Read the VDC out, then obtain the RH value from the equation. The slope of the sensors' output equation (VDC out per 1 % RH change) is 29 mV/%RH (off-set 0.78 VDC) for the Model HC-610. Some DMM's have a relative mode button, allowing for the zeroing of the off-set. The DMM should have a nominal 10 megohms input impedance. For a direct reading of RH, the circuit diagram in Fig. 2 can be used. The LCD display is available from OHMIC INSTRUMENTS CO.

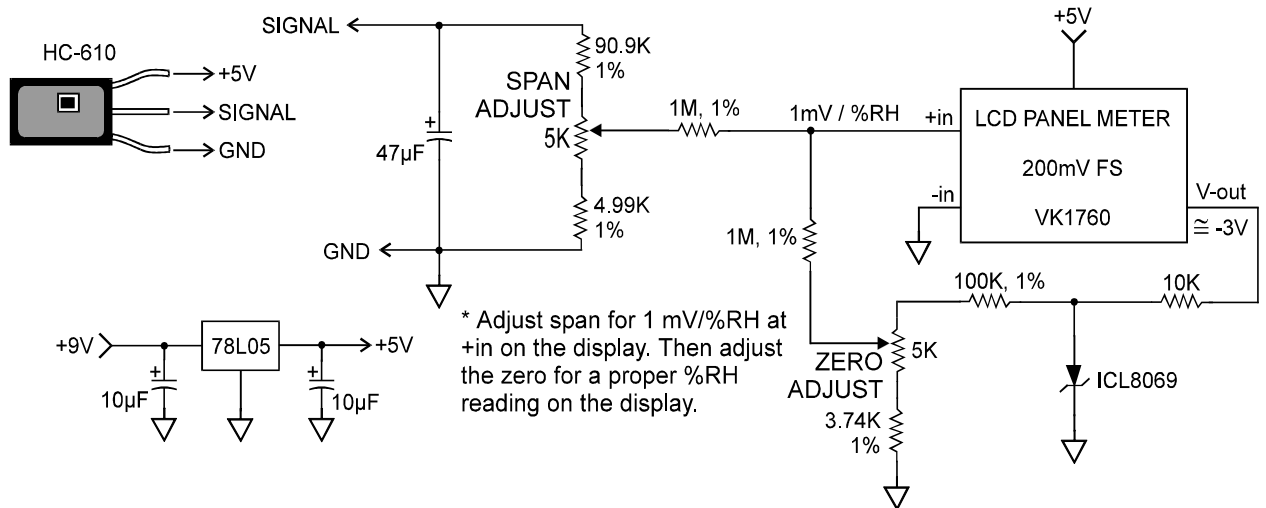

HUMIDITY CONTROL CIRCUIT

The humidity controller circuit diagram in Fig. 3 accepts capacitive or resistive sensor transmitters. The input signal is filtered and attenuated for improved dynamic range and is applied to the non-inverting input (+) of an op-amp configured as a comparator. Its switch point is selectable by the potentiometer with resistance values as indicated over the full dynamic range of the signal conditioner. The set point selection is made by applying a DC voltage to the inverting input (-) signal input with the selected value from the given equations. Once the set point is exceeded, the output of the op-amp turns on the mosfet to activate the 5V relay.

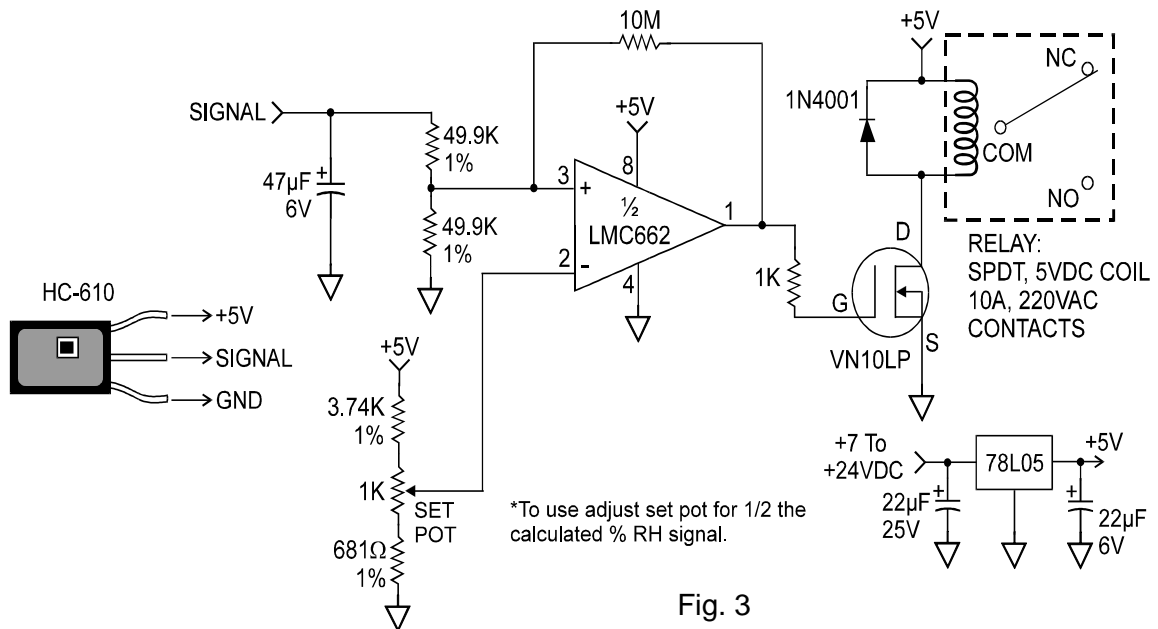

Fig. 3

NOTES: