

WARRANTY

Notwithstanding any provision of any agreement the following warranty is exclusive.

Ohmic Instruments COMPANY warrants each instrument it manufactures to be free from defects in material and workmanship under normal use and service for the period of 1-year from date of purchase. This warranty extends only to the original purchaser. This warranty shall not apply to fuses or any product or parts which have been subjected to misuse, neglect, accident, or abnormal conditions of operation.

In the event of failure of a product covered by this warranty, Ohmic Instruments Co. will repair and recalibrate an instrument returned within 1 year of the original purchase: provided the warrantor's examination discloses to its satisfaction that the product was defective. The warrantor may, at its option, replace the product in lieu of repair. With regard to any instrument returned within 1 year of the original purchase, said repairs or replacement will be made without charge. If the failure has been caused by misuse, neglect, accident, or abnormal conditions of operations, repairs will be billed at a nominal cost. In such case, an estimate will be submitted before work is started, if requested.

THE FOREGOING WARRANTY IS IN LIEU OF ALL OTHER WARRANTIES, EXPRESS OR IMPLIED, INCLUDING BUT NOT LIMITED TO ANY IMPLIED WARRANTY OF MERCHANTABILITY, FITNESS, OR ADEQUACY FOR ANY PARTICULAR PURPOSE OR USE. OHMIC INSTRUMENTS COMPANY SHALL NOT BE LIABLE FOR ANY SPECIAL, INCIDENTAL, OR CONSEQUENTIAL DAMAGES, WHETHER IN CONTRACT, TORT, OR OTHERWISE.

If any failure occurs, the following steps should be taken:

1. Notify Ohmic Instruments Co. giving full details of the difficulty, and include the model, type, and serial numbers (where applicable). On receipt of this information, service data, or shipping instructions will be forwarded to you.

2. On receipt of shipping instructions, forward the instrument, transportation prepaid. Repairs will be made and the instrument returned, transportation prepaid.

SHIPPING TO MANUFACTURER FOR REPAIR OR ADJUSTMENT

All shipments of Ohmic Instruments Co. instruments should be made via United Parcel Service or "Best Way" prepaid. The instrument should be shipped in the original packing carton, or if it is not available, use any suitable container that is rigid and of adequate size. If a substitute container is used, the instrument should be wrapped in paper and surrounded with at least four inches of excelsior or similar shock absorbing material.

CLAIM FOR DAMAGE IN SHIPMENT TO ORIGINAL PURCHASER

The instrument should be thoroughly inspected immediately upon delivery to purchaser. All material in the shipping container should be checked against the enclosed packing list. The manufacturer will not be responsible for shortages against the packing sheet unless notified immediately. If the instrument is damaged in any way, a claim should be filed with the carrier immediately. (To obtain a quotation to repair shipment damage, contact Ohmic Instruments.) Final claim and negotiations with the carrier must be completed by the customer.

Ohmic Instruments Company will be pleased to answer all application or use questions, which will enhance your use of this instrument. Please address your requests or correspondence to: Ohmic Instruments Company, 508 August St., Easton, Maryland 21601, ATTN: Technical Support. Or call Ohmic Technical Support at 410-820-5111.

All rights reserved. This manual may not be reproduced in full or in part without written permission of Ohmic Instruments Company. Information contained within this manual is believed to be accurate and reliable. However, Ohmic Instruments Company assumes no liability for its use. Ohmic Instruments Company reserves the right to supply its instruments with design changes and/or component substitutions that may not be documented in this manual. Contact our engineering department for information on equipment revisions not covered in this manual.

ohmic instruments co.



ohmic instruments co.

508 August Street Easton, MD 21601

www.ohmicinstruments.com

FAX (410) 820-5111
(410) 822-9633 (410) 822-4844

PORTABLE DEW POINT MONITOR

Model DPM-35XR

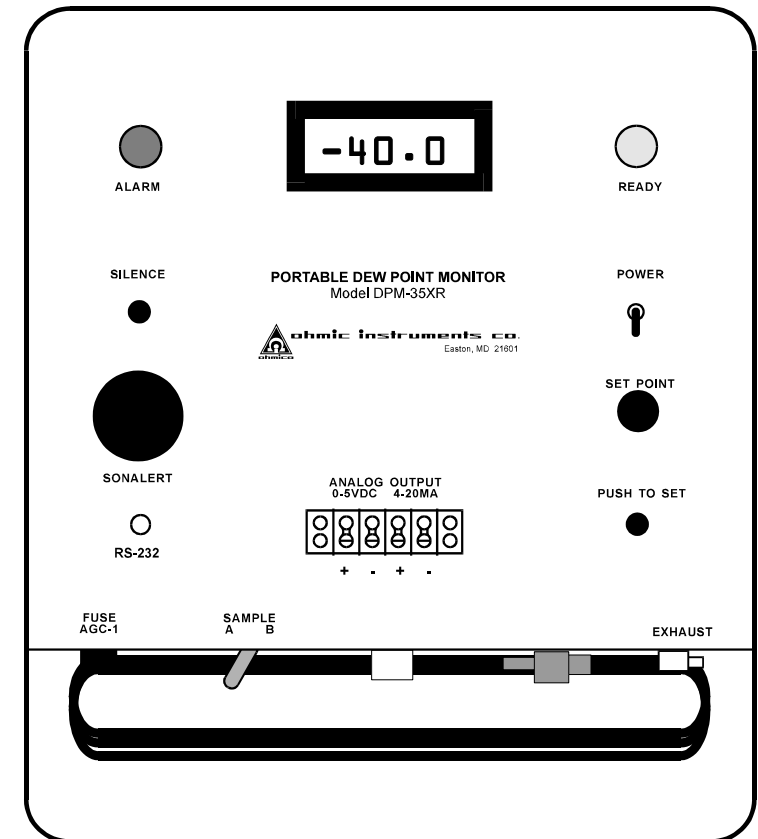

OPERATING NOTES

LOGGING COMMANDS FOR LOGGER VERSION ONLY (DPM-35XRL)

1. When the unit is powered up, the computer's screen will display the following:

Mm/dd/yy hh:mm:ss (RH%) (Temp) (Dew Point) (Set Point)

To reset the time stamp while connected to a computer :

Type TMM DD YY hh mm ss then press "enter"

Set date and time for real time clock:

MM = month (01--12)

DD = day (01--31)

YY = year (00--99)

hh = hours (00--23)

mm = minutes (00--59)

ss = seconds (00--59)

2. A maximum of 2383 readings can be stored; however, once the memory logging space has been filled, a wrap feature of the memory storing will cause the oldest data to be overwritten. Thus, when the memory is full, the logger will hold a "sliding window" spanning 2383 readings.

Uploading the logged data can be done at any point. The stored readings are transmitted chronologically, each line of the display corresponding to one scan of the sensors. For a full logger memory of 2383 readings, uploading takes approximately three minutes. Note, however, that a slow scrolling speed of the terminal screen might stretch this interval to about four and a half minutes.

Uploading will not clear the logger memory; this makes repeated uploading of the same data possible. Data will be stored in the nonvolatile memory incorporated into the logger, without having power applied to the unit, for as long as ten years.

3. The following commands apply to the logger version (DPM-35XRL) only:

S<Enter> Transmits current settings of parameters: C#, L#, N#
(C is autotransmit data in seconds,
L is logging rate in seconds,
N is number of readings logged, 0 to 2383)

Ln<Enter> Set logging rate to "n" seconds ("n" is 3 to 32767).
For n=0, 1, 2, logging is off.

E9090<Enter> Clear stored data.

U<Enter> Upload stored data. Readings, including a time stamp, are transmitted in chronological order, one line corresponding to one scan of the sensors.

H<Enter> Halt the uploading of data. This command will work only when uploading is in progress.

When halted, only two commands are accepted:

Q<Enter> Terminate the uploading in progress and resume the measurement and logging functions. This command will work only following the "halt" command (**H**).

U<Enter> Resume loading. This command will work only following the "halt" command (**H**).

4. The unit will not log when power is turned off.

© Ohmic Instruments Company
2006

REPLACEMENT PARTS

Desiccant Cartridge.....	Ohmic #13050
½ Amp Fuse.....	Ohmic #5475
In-Line Filter	Ohmic #5355
Status Lamps	Ohmic #7245

Ohmic Instruments offers a tune-up service which consists of replacing the sensor, recalibration of the unit, and replacement of the tubing, desiccant, and filter. Contact Ohmic Instruments for pricing on this service.

If you need additional help for your particular application, contact:

Ohmic Instruments Company
(410) 820-5111
ohmic@ohmicinstruments.com

Contents

Introduction.....	5
Sample Modes.....	6
Analog Output Table.....	8
Operation	9
Functional Test	9
RS-232 Interface	10
Communications Commands.....	11
Sensor Precautions	12
Specifications.....	13
Replacement Parts	14
Commands (Logger Version only).....	15
Warranty	16

SENSOR PRECAUTIONS

The following is a list of limits of operation. Exceeding these limits can cause sensor failure and voids all warranties.

- I. Humidity.....1 to 99% RH - NON CONDENSING
- II. Temperature.....0 to 185°F
- III. Max. Pressure.....125 psi
- IV. Electrical.....Never connect the sensor probe to any other device; the signal conditioning circuitry in the DPM-35XR is specific to the sensor. **Connecting the sensor to other circuitry or meters (including multimeters) can cause damage to the sensor.**
- V. Particulate Contamination.....The sensors should be shielded from particulate contaminants. The in-line filter should always be used, especially when the quality of the air is in question. Never sample air of gases with oil mist or separated water.
- VI. Chemical Contamination.....Exposure to corrosive or reactive chemicals should be avoided. Chemicals, such as sulfides, acids, and mercury will cause permanent damage.

INTRODUCTION

The Portable Dew Point Monitor Model DPM-35XR is a microprocessor-based instrument used to monitor the output air from dryer systems. The DPM-35XR determines the dew point temperature by measuring the humidity and dry bulb temperature. These dew point calculations are compensated using pre-programmed psychrometric equations.

Features of the standard model include:

- Plastic carrying case that allows transportation to various dryer locations
- A 3-½ digit LCD dew point readout which is accurate from -40° to +80°F
- 3-position power switch: *Up*: electronics on and pump on for low pressure systems. *Center*: off. *Down*: electronics on and pump off for compressed air systems
- A-B selector switch: A for low pressure dryer systems; B for compressed air systems
- Variable set point, adjustable by means of a front panel potentiometer
- Audible alarm indicator that can be silenced by momentarily depressing a pushbutton switch
- Two indicator lamps: red lamp (alarm) lights when dew point is above setpoint, green lamp (ready) is on for dew point temperatures below the set point
- Dew Point analog outputs for signal transmission to recorders and data loggers (0-5V DC / 4-20mA DC), and RS-232 output.

SAMPLE MODES

The DPM-35XR is designed for use with both compressed and low pressure air systems. In both cases, the sample air passes through a heat exchange coil to adjust the air temperature to below 185°F. The sample air then enters a sensor manifold where the humidity and temperature are measured with model PDPS-610TH Moisture / Temperature probe. The microprocessor uses the water vapor and dry bulb temperature measurement of the sampled air to calculate the dew point. This process is illustrated in Figure 1.

Monitoring Plastic Resin Dryers, Ovens and Low Pressure Vessels

In low pressure air applications (pressure less than 5 PSIG), a vacuum pump is used to draw the sample air into the sensor manifold. The A-B switch should be placed in the "A" position and the Power switch should be placed in the up position. When sampling from flexible air ducts, a suitable right angle tubing piece should be installed such that the airflow into the monitor inlet tube is parallel to the flow through the duct. This requirement is necessary because sometimes when sampling from air ducts where the tubing position is perpendicular to the air flow, a venturi effect will create enough negative pressure to reverse the flow through the instrument.

Monitoring Compressed Air or Pressurized Vessels

In compressed-air applications, the dew point measurements are made at line, rather than atmospheric pressure, eliminating the need to calculate pressure dew points. The air is vented through an orifice which maintains the back pressure on the probe. The A-B selector switch should be in the "B" position and the Power switch should be in the down position. The inlet pressure should not exceed 125 PSIG. To mate to pressurized air lines or vessels, use 1/4" OD compression fittings to mate to the supplied 1/4" pneumatic tubing.

WARNING!

DO NOT CONNECT TO AN AIR/GAS SOURCE GREATER THAN 5 PSI WHILE THE UNIT IS IN THE "A" SAMPLING MODE. FOR COMPRESSED AIR GREATER THAN 5 PSI THE SELECTOR SWITCH SHOULD BE IN THE "B" POSITION. APPLYING A PRESSURE GREATER THAN 5 PSI WHILE IN THE "A" POSITION WILL DAMAGE THE INTERNAL PUMP.

configure HyperTerminal to communicate with the DPM-35XR, start the program; you will get a box asking for a name for the new connection. Type in a name, such as DPM, select an icon and click OK. In the next window that comes up, go to the drop-down box and select the COM port you wish to use. Click on OK. You will then see a window where you can configure your connection. Select these items in the drop-down boxes: For Bits per Second, select 9600. For Data Bits, select 8. For Parity, select None. For Stop bits, select 1. For Flow Control, select Xon/Xoff. Now click on OK.

HyperTerminal is now ready to receive data from the DPM-35XR. Make sure they are connected via the adapter cable, and power up the DPM-35XR. Introductory text will be displayed indicating the version of the imbedded program. The computer will then display four numbers: Relative Humidity, Dry Bulb Temperature, Dew Point, and Set Point. New readings will be displayed every few seconds.

* If the readings are not displayed, turn DPM-35XR off, disconnect HyperTerminal by clicking on the Phone icon in the task bar. Go to File/Properties. In this box change the "Connect using:" box to another COM port and try again. Once you get a working display remember to save those settings as described below.

To save your settings: Go to the menu bar, select File, then select Save. Then, next time you start HyperTerminal, simply cancel out of the New Connection window, then select Open from the File menu, click on the name you gave your settings, and click on Open. You can now use HyperTerminal to communicate without reconfiguring. For more convenience, you may want to drag the desired name from the Open dialog box to your desktop using the mouse; this will place an icon there that you can double-click to start your session.

Communications Commands

All commands are in upper-case characters (set your **CAPS LOCK** on). *n* indicates where a number must be entered.

Cn<Enter> Set auto data transmit interval for displayed readings to *n* seconds (*n* is an integer from 3 to 32767). For *n*=0, 1, and 2, automatic transmission is turned off. Default value is *n*=3 seconds.

D<Enter> Transmits the latest set of readings.

S<Enter> Transmit current settings of parameters.

Note: To enable the screen to display what you are typing, go to the menu bar in HyperTerminal, click on File, select Properties, click on the Settings tab, click on the ASCII Setup button, and checkmark the "Echo typed characters locally" box.

3. Set the A-B selector switch in the "A" position.
4. Move the Power switch on the DPM-35XR to the Up position. Within 5-10 minutes, the dew point reading should decrease below 0°F.

When used in plastics drying operations, hydrocarbons from the out gas of the plastic resin might condense over time on the sensor. The varnish that forms will slow the response time of the sensing element. Eventually the sensor may have to be replaced; therefore, the filter should not be bypassed and should be replaced regularly. Should the response slow down considerably the unit should be returned for sensor replacement and calibration.

The DPM-35XR is a microprocessor-based instrument. It has no user calibration adjustments. The unit can be recertified to NIST traceable standards by returning it to Ohmic Instruments. Certification is valid for one year and is recommended on a yearly basis. Calibration consists of a computer based system to program a 9-point calibration curve which is stored in the unit's EEPROM. The calibration is referenced to a NIST traceable chilled mirror.

RS-232 INTERFACE– Connecting the DPM-35XR to your Computer

Connecting to a serial port The DPM-35XR can be plugged into any 9-pin PC serial (COM) port using the enclosed adapter cable. If your computer has a 25-pin COM port, 25-pin to 9-pin serial adapters are available from most computer stores and can be used with the adapter cable [Serial data is transmitted using Pin 5 (ground), Pin 3 (transmit), and Pin 2 (receive)]. Some computer COM ports and serial adapters are not fully implemented (not all pins are used). If the DPM-35XR is connected to a partially implemented serial port, functions may be erratic or the unit may fail to communicate. Consult the owner's manual for your computer if this occurs. Set up HyperTerminal as described next in Communications Programs.

Connecting to a USB port If your computer has USB ports you can get an optional RS-232 to USB adapter from Ohmic. Ohmic recommends using an RS-232 to USB adapter only with Windows XP® and Windows Vista®. Connect the DPM-35XR using the RS-232 adapter and RS-232 to USB adapter. Turn on your computer. When your computer recognizes the device click OK and follow the instructions for installing the driver software. Set up HyperTerminal as described next in Communications Programs.

Communications Programs

The DPM-35XR transmits data via its RS-232 output as soon as it is powered up. In order to receive the data, a communications program must be running on your computer. In Windows 95® and later this will be *HyperTerminal*. To

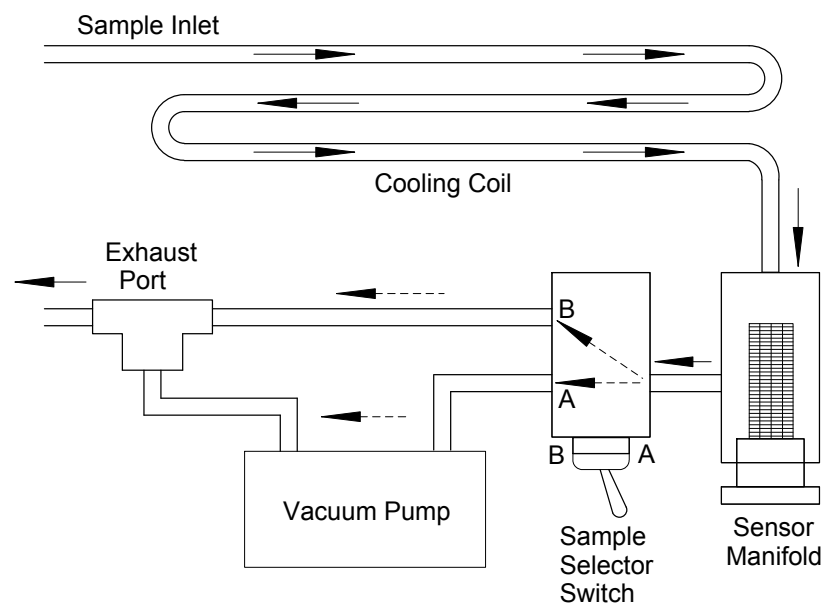

Figure 1

F-DP	V-out	I-out	F-DP	V-out	I-out	F-DP	V-out	I-out	F-DP	V-out	I-out
-45	0.000	4.000	-11	1.259	8.030	23	2.519	12.059	57	3.778	16.089
-44	0.037	4.119	-10	1.296	8.148	24	2.556	12.178	58	3.815	16.207
-43	0.074	4.237	-9	1.333	8.267	25	2.593	12.296	59	3.852	16.326
-42	0.111	4.356	-8	1.370	8.385	26	2.630	12.415	60	3.889	16.444
-41	0.148	4.474	-7	1.407	8.504	27	2.667	12.533	61	3.926	16.563
-40	0.185	4.593	-6	1.444	8.622	28	2.704	12.652	62	3.963	16.681
-39	0.222	4.711	-5	1.481	8.741	29	2.741	12.770	63	4.000	16.800
-38	0.259	4.830	-4	1.519	8.859	30	2.778	12.889	64	4.037	16.919
-37	0.296	4.948	-3	1.556	8.978	31	2.815	13.007	65	4.074	17.037
-36	0.333	5.067	-2	1.593	9.096	32	2.852	13.126	66	4.111	17.156
-35	0.370	5.185	-1	1.630	9.215	33	2.889	13.244	67	4.148	17.274
-34	0.407	5.304	0	1.667	9.333	34	2.926	13.363	68	4.185	17.393
-33	0.444	5.422	1	1.704	9.452	35	2.963	13.481	69	4.222	17.511
-32	0.481	5.541	2	1.741	9.570	36	3.000	13.600	70	4.259	17.630
-31	0.519	5.659	3	1.778	9.689	37	3.037	13.719	71	4.296	17.748
-30	0.556	5.778	4	1.815	9.807	38	3.074	13.837	72	4.333	17.867
-29	0.593	5.896	5	1.852	9.926	39	3.111	13.956	73	4.370	17.985
-28	0.630	6.015	6	1.889	10.044	40	3.148	14.074	74	4.407	18.104
-27	0.667	6.133	7	1.926	10.163	41	3.185	14.193	75	4.444	18.222
-26	0.704	6.252	8	1.963	10.281	42	3.222	14.311	76	4.481	18.341
-25	0.741	6.370	9	2.000	10.400	43	3.259	14.430	77	4.519	18.459
-24	0.778	6.489	10	2.037	10.519	44	3.296	14.548	78	4.556	18.578
-23	0.815	6.607	11	2.074	10.637	45	3.333	14.667	79	4.593	18.696
-22	0.852	6.726	12	2.111	10.756	46	3.370	14.785	80	4.630	18.815
-21	0.889	6.844	13	2.148	10.874	47	3.407	14.904	81	4.667	18.933
-20	0.926	6.963	14	2.185	10.993	48	3.444	15.022	82	4.704	19.052
-19	0.963	7.081	15	2.222	11.111	49	3.481	15.141	83	4.741	19.170
-18	1.000	7.200	16	2.259	11.230	50	3.519	15.259	84	4.778	19.289
-17	1.037	7.319	17	2.296	11.348	51	3.556	15.378	85	4.815	19.407
-16	1.074	7.437	18	2.333	11.467	52	3.593	15.496	86	4.852	19.526
-15	1.111	7.556	19	2.370	11.585	53	3.630	15.615	87	4.889	19.644
-14	1.148	7.674	20	2.407	11.704	54	3.667	15.733	88	4.926	19.763
-13	1.185	7.793	21	2.444	11.822	55	3.704	15.852	89	4.963	19.881
-12	1.222	7.911	22	2.481	11.941	56	3.741	15.970	90	5.000	20.000

Table 1—Analog Output Table

OPERATION

1. Connect the plastic inlet hose provided with the monitor to the dry air test port and select the correct position for the A-B selector switch. Care should be taken not to subject the unit to unnecessary vibration or extreme temperature (when sampling from plastic dryers and ovens, dry bulb temperature of air source should not exceed 500°F).
2. Make connections to output terminals located on the front of the unit and labeled to their function. For analog output values refer to the output table, Table 1.
3. Plug the monitor into a 120V AC, 60Hz outlet and turn power on—Up if the A-B selector switch is in the “A” position, Down if the selector switch is in the “B” position.
4. Set the alarm set point by pressing the PUSH TO SET button and turning the front panel knob until the appropriate set point is displayed.
5. Wait for the dew point reading to stabilize. The monitor range is limited by the response of the internal sensor. There is no over/under range indication, and the accuracy is not rated beyond specified system limits.
6. The green lamp indicates a measurement below the set point. The red alarm lamp and piezo buzzer will indicate when the set point has been exceeded. The sonalert can be silenced by depressing the SILENCE push button.

FUNCTIONAL TEST

A desiccant cartridge is included with the DPM-35XR unit to functionally test the instrument. Before running the functional test, check the color of the desiccant. It should be bright blue. When the desiccant absorbs water vapor, it turns pink. If the entire tube is pink, replace the cartridge (check the replacement parts list at the end of the manual).

Follow this procedure to test the DPM-35XR or “dry down” the sensor to have quicker system response:

1. Remove end caps from the cartridge and, using the supplied plastic tubing, connect one end to the cooling coil. Make sure the arrows on the desiccant cartridge point in the direction of the air flow.
2. Connect the other end of the desiccant cartridge to the exhaust port, resulting in a closed loop.