



ohmic instruments co.

508 August Street Easton, MD 21601

www.ohmicinstruments.com

FAX
(410) 822-9633

(410) 820-5111
(410) 822-4844

DEW POINT MONITOR
In NEMA Enclosure
Model DPM-35XRN
And **DPM-35XRNL**

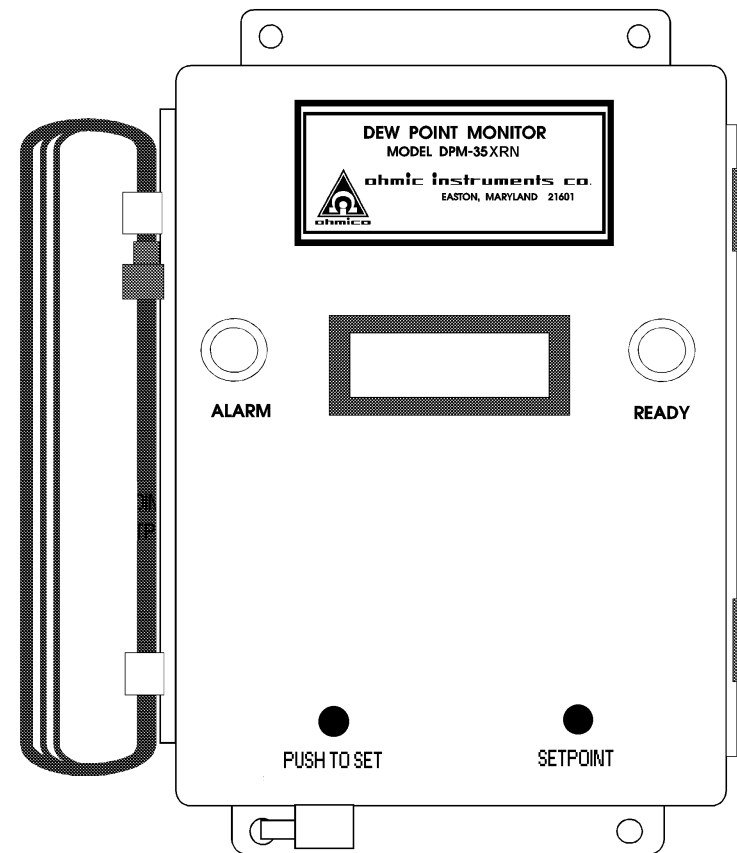

OPERATING NOTES

© Ohmic Instruments Company
2006

WARRANTY

Notwithstanding any provision of any agreement the following warranty is exclusive.

Ohmic Instruments COMPANY warrants each instrument it manufactures to be free from defects in material and workmanship under normal use and service for the period of 1-year from date of purchase. This warranty extends only to the original purchaser. This warranty shall not apply to fuses or any product or parts which have been subjected to misuse, neglect, accident, or abnormal conditions of operation.

In the event of failure of a product covered by this warranty, Ohmic Instruments Co. will repair and recalibrate an instrument returned within 1 year of the original purchase: provided the warrantor's examination discloses to its satisfaction that the product was defective. The warrantor may, at its option, replace the product in lieu of repair. With regard to any instrument returned within 1 year of the original purchase, said repairs or replacement will be made without charge. If the failure has been caused by misuse, neglect, accident, or abnormal conditions of operations, repairs will be billed at a nominal cost. In such case, an estimate will be submitted before work is started, if requested.

THE FOREGOING WARRANTY IS IN LIEU OF ALL OTHER WARRANTIES, EXPRESS OR IMPLIED, INCLUDING BUT NOT LIMITED TO ANY IMPLIED WARRANTY OF MERCHANTABILITY, FITNESS, OR ADEQUACY FOR ANY PARTICULAR PURPOSE OR USE. OHMIC INSTRUMENTS COMPANY SHALL NOT BE LIABLE FOR ANY SPECIAL, INCIDENTAL, OR CONSEQUENTIAL DAMAGES, WHETHER IN CONTRACT, TORT, OR OTHERWISE.

If any failure occurs, the following steps should be taken:

1. Notify Ohmic Instruments Co. giving full details of the difficulty, and include the model, type, and serial numbers (where applicable). On receipt of this information, service data, or shipping instructions will be forwarded to you.

2. On receipt of shipping instructions, forward the instrument, transportation prepaid. Repairs will be made and the instrument returned, transportation prepaid.

SHIPPING TO MANUFACTURER FOR REPAIR OR ADJUSTMENT

All shipments of Ohmic Instruments Co. instruments should be made via United Parcel Service or "Best Way" prepaid. The instrument should be shipped in the original packing carton, or if it is not available, use any suitable container that is rigid and of adequate size. If a substitute container is used, the instrument should be wrapped in paper and surrounded with at least four inches of excelsior or similar shock absorbing material.

CLAIM FOR DAMAGE IN SHIPMENT TO ORIGINAL PURCHASER

The instrument should be thoroughly inspected immediately upon delivery to purchaser. All material in the shipping container should be checked against the enclosed packing list. The manufacturer will not be responsible for shortages against the packing sheet unless notified immediately. If the instrument is damaged in any way, a claim should be filed with the carrier immediately. (To obtain a quotation to repair shipment damage, contact Ohmic Instruments.) Final claim and negotiations with the carrier must be completed by the customer.

Ohmic Instruments Company will be pleased to answer all application or use questions, which will enhance your use of this instrument. Please address your requests or correspondence to: Ohmic Instruments Company, 508 August St., Easton, Maryland 21601, ATTN: Technical Support. Or call Ohmic Technical Support at 410-820-5111.

All rights reserved. This manual may not be reproduced in full or in part without written permission of Ohmic Instruments Company. Information contained within this manual is believed to be accurate and reliable. However, Ohmic Instruments Company assumes no liability for its use. Ohmic Instruments Company reserves the right to supply its instruments with design changes and/or component substitutions that may not be documented in this manual. Contact our engineering department for information on equipment revisions not covered in this manual.

Contents

Introduction5

Sample Modes6

Installation and Operation.....8

Connection Layout.....9

Analog Output Table.....10

Functional Test11

Recalibration.....11

RS-232 Interface12

Communications Commands13

Sensor Precautions14

Specifications.....15

Replacement Parts16

Logging Commands (Logger Version only).....17

Warranty18

LOGGING COMMANDS FOR LOGGER VERSION ONLY (DPM-35XRNL)

1. When the unit is powered up, the computer's screen will display the following:

Mm/dd/yy hh:mm:ss (RH%) (Temp) (Dew Point) (Set Point)

2. A maximum of 2383 readings can be stored; however, once the memory logging space has been filled, a wrap feature of the memory storing will cause the oldest data to be overwritten. Thus, when the memory is full, the logger will hold a "sliding window" spanning 2383 readings.

Uploading the logged data can be done at any point. The stored readings are transmitted chronologically, each line of the display corresponding to one scan of the sensors. For a full logger memory of 2383 readings, uploading takes approximately three minutes. Note, however, that a slow scrolling speed of the terminal screen might stretch this interval to about four and a half minutes.

Uploading will not clear the logger memory; this makes repeated uploading of the same data possible. Data will be stored in the nonvolatile memory incorporated into the logger, without having power applied to the unit, for as long as ten years.

3. The following commands apply to the logger version (DPM-35XRNL) only:

S <Enter>	Transmits current settings of parameters: C#, L#, N# (C is autotransmit data in seconds, L is logging rate in seconds, N is number of readings logged, 0 to 2383)
Ln <Enter>	Set logging rate to "n" seconds ("n" is 3 to 32767). For n=0, 1, 2, logging is off.
E9090 <Enter>	Clear stored data.
U <Enter>	Upload stored data. Readings, including a time stamp, are transmitted in chronological order, one line corresponding to one scan of the sensors.
H <Enter>	Halt the uploading of data. This command will work only when uploading is in progress.

When halted, only two commands are accepted:

Q <Enter>	Terminate the uploading in progress and resume the measurement and logging functions. This command will work only following the "halt" command (H).
U <Enter>	Resume loading. This command will work only following the "halt" command (H).

4. The unit will not log when power is turned off.

REPLACEMENT PARTS

Desiccant Cartridge.....	Ohmic #13050
Sensor.....	PDPS-610TH
½ Amp Fuse.....	Ohmic #5490
In-Line Filter.....	Ohmic #5355
Vacuum Pump.....	Ohmic #10620
Status Lamps.....	Ohmic #7245

If you need additional help for your particular application, contact:

Ohmic Instruments Company
(410) 820-5111
ohmic@ohmicinstruments.com

INTRODUCTION

Ohmic's **Dew Point Monitor** Model DPM-35XRN (and DPM-35XRNL, the time-stamp logging version) is a microprocessor-based instrument used to monitor the output air from dryer systems. The DPM-35XRN determines the dew point temperature by measuring the humidity and dry bulb temperature. These dew point calculations are compensated for variations in sample dry bulb temperature using pre-programmed psychrometric equations.

Features of the standard model include:

- Steel NEMA-12 enclosure designed for wall mounting
- A 3-½ digit LCD dew point readout which is accurate from -40° to +80°F
- A-B selector switch: A for low pressure dryer systems; B for compressed air systems
- Variable set point, adjustable by means of a front panel potentiometer
- Two indicator lamps: red lamp (alarm) lights when dew point is above setpoint, green lamp (ready) is on for dew point temperatures below the set point
- Dew Point analog outputs for signal transmission to recorders and data loggers (0-5V DC / 4-20mA DC), and RS-232 output.
- Relay contacts for remote alarm or control
- Selectable scale for temperature display (degrees Fahrenheit or Celsius)

The DPM-35XRN and DPM-35XRNL are identical, except for the inclusion of a time-stamp logging function on the latter.

SENSOR PRECAUTIONS

The following is a list of limits of operation. Exceeding these limits can cause sensor failure and voids all warranties.

I. Humidity.....1 to 99% RH - NON CONDENSING

II. Temperature.....0 to 185°F

III. Max. Pressure.....125 psi

IV. Electrical.....Never connect the sensor probe to any other device; the signal conditioning circuitry in the DPM-35XRN is specific to the sensor. **Connecting the sensor to other circuitry or meters (including multimeters) can cause damage to the sensor.**

V. Particulate Contamination.....The sensors should be shielded from particulate contaminants. The in-line filter should always be used, especially when the quality of the air is in question. Never sample air of gases with oil mist or separated water.

VI. Chemical Contamination.....Exposure to corrosive or reactive chemicals should be avoided. Chemicals, such as sulfides, acids, and mercury will cause permanent damage.

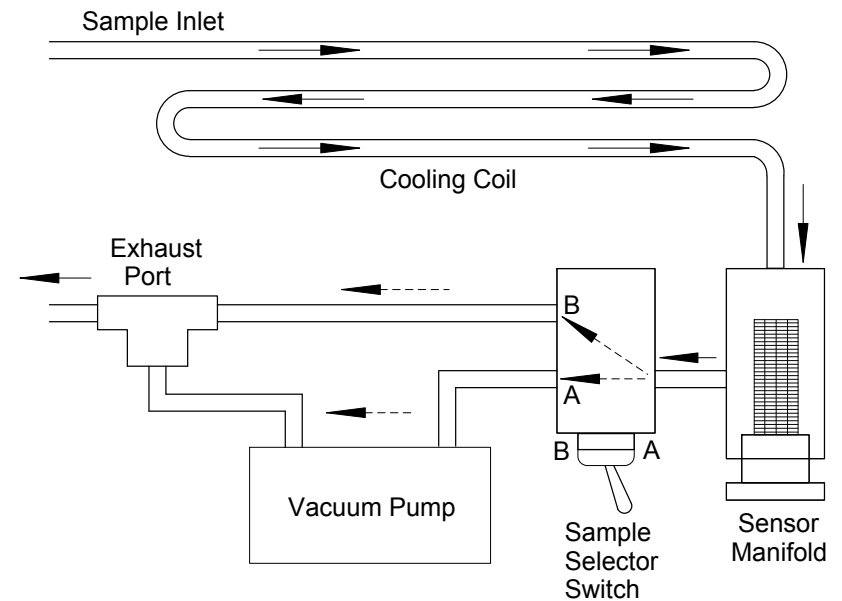

Figure 1

INSTALLATION AND OPERATION

1. Securely mount the unit, in close proximity to the sample source, to a wall or similar structure capable of supporting its weight. Care should be taken not to subject the unit to unnecessary vibration or extreme temperature (when sampling from plastic dryers and ovens, dry bulb temperature of air source should not exceed 500°F). The DPM-35XRN is not intended to withstand direct water spray.

2. Electrical connections will be made via two ½" conduit cutouts in the bottom of the unit. We recommend that low-voltage signals (analog outputs, remote alarms, etc.) be routed separately from high-voltage (line power, controlled device, etc.). For all connections, refer to the layout in Fig. 2 (Page 9). The 120 VAC line and controlled relay contact terminals are located on the main circuit board and are labeled as to their function. The analog output (0-5 VDC & 4-20mA) terminals are located on the back panel, and are also labeled. For output values refer to output table on Page 10.

-- Electrical connections should be made only by a qualified electrician--

3. Connect the plastic inlet hose from the blue filter on the DPM-35XRN to the dry air test port and select the correct position for the A-B switch (A for testing low pressure systems, B for high pressure).

Place the selector switch on the main circuit board in the desired position (see Figure 2) for either °C or °F operation. Whenever this switch is changed, the setting will not be implemented until the unit is reset by shutting off the power and reenergizing the circuit.

4. Connect the unit to a 120 VAC, 60 Hertz power supply.

5. Set the alarm setpoint by pressing the "Push to Set" pushbutton and turning the front panel slotted potentiometer until the desired setpoint is shown on the LCD display. This potentiometer can be locked down by tightening the nut on the shaft.

6. Wait for the Dew Point reading to stabilize. The monitor range is limited by the response of the internal sensor. There is no over/under range indication, and the accuracy is not rated beyond specified system limits.

7. The green lamp indicates a measurement below the set point. The red lamp indicates when the set point has been exceeded.

* If the readings are not displayed, turn DPM-35XRN off, disconnect HyperTerminal by clicking on the Phone icon in the task bar. Go to File/Properties. In this box change the "Connect using:" box to another COM port and try again. Once you get a working display remember to save those settings as described below.

To save your settings: Go to the menu bar, select File, then select Save. Then, next time you start HyperTerminal, simply cancel out of the New Connection window, then select Open from the File menu, click on the name you gave your settings, and click on Open. You can now use HyperTerminal to communicate without reconfiguring. For more convenience, you may want to drag the desired name from the Open dialog box to your desktop using the mouse; this will place an icon there that you can double-click to start your session.

Communications Commands

All commands are in upper-case characters (set your **CAPS LOCK** on). *n* indicates where a number must be entered.

[Information specific to the DPM-35XRNL (time-stamp logging version) appears on page 17.]

C*n*<Enter> Set auto data transmit interval for displayed readings to *n* seconds (*n* is an integer from 3 to 32767). For *n*=0, 1, and 2, automatic transmission is turned off. Default value is *n*=3 seconds.

D<Enter> Transmits the latest set of readings.

S<Enter> Transmit current settings of parameters.

Note: If the screen does not display what you are typing, go to the menu bar in HyperTerminal, click on File, select Properties, click on the Settings tab, click on the ASCII Setup button, and checkmark the "Echo typed characters locally" box.

RS-232 INTERFACE– Connecting the DPM-35XRN to your Computer

Connecting to a serial port The DPM-35XRN can be plugged into any 9-pin PC serial (COM) port using a 9-pin serial cable, available from most computer stores. If your computer has a 25-pin COM port, 25-pin to 9-pin serial adapters are also available from most computer stores and can be used with the cable [Serial data is transmitted using Pin 5 (ground), Pin 3 (transmit), and Pin 2 (receive)]. Some computer COM ports and serial adapters are not fully implemented (not all pins are used). If the DPM-35XRN is connected to a partially implemented serial port, functions may be erratic or the unit may fail to communicate. Consult the owner's manual for your computer if this occurs. Set up HyperTerminal as described next in Communications Programs.

Connecting to a USB port If your computer has USB ports you can get an optional RS-232 to USB adapter from Ohmic. Ohmic recommends using an RS-232 to USB adapter only with Windows XP® and Windows Vista®. Connect the DPM-35XRN using the RS-232 adapter and RS-232 to USB adapter. Turn on your computer. When your computer recognizes the device click OK and follow the instructions for installing the driver software. Set up HyperTerminal as described next in Communications Programs.

Communications Programs

The DPM-35XRN transmits data via its RS-232 output as soon as it is powered up. In order to receive the data, a communications program must be running on your computer. In Windows 95® and later this will be *HyperTerminal*. To configure HyperTerminal to communicate with the DPM-35XRN, start the program; you will get a box asking for a name for the new connection. Type in a name, such as DPM, select an icon and click OK. In the next window that comes up, go to the drop-down box and select the COM port you wish to use. Click on OK. You will then see a window where you can configure your connection. Select these items in the drop-down boxes: For Bits per Second, select 9600. For Data Bits, select 8. For Parity, select None. For Stop bits, select 1. For Flow Control, select Xon/Xoff. Now click on OK.

HyperTerminal is now ready to receive data from the DPM-35XRN. Make sure they are connected via the serial cable, and power up the DPM-35XRN. Introductory text will be displayed indicating the version of the imbedded program. The computer will then display four numbers: Relative Humidity, Dry Bulb Temperature, Dew Point, and Set Point. New readings will be displayed every few seconds.

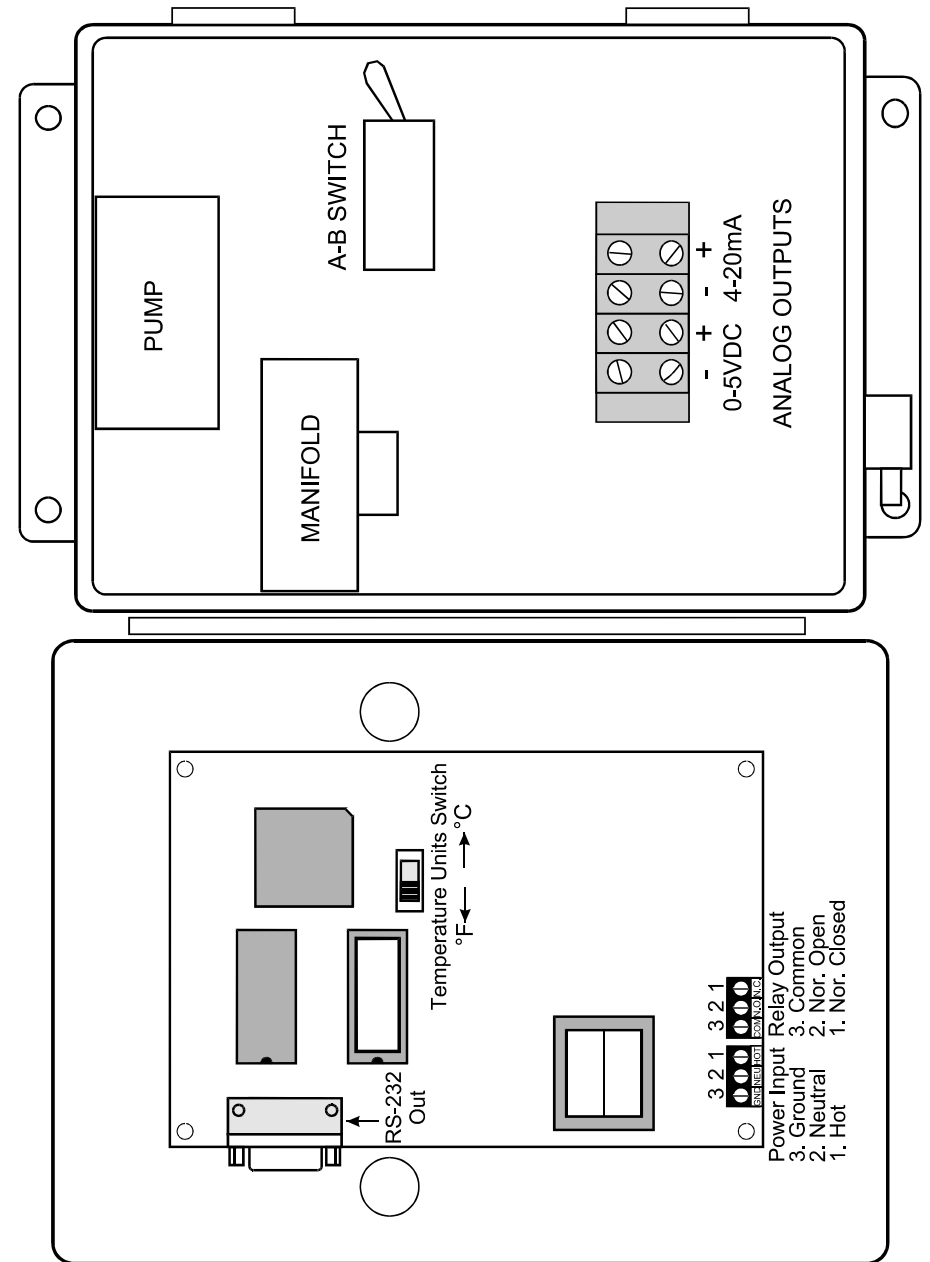

Figure 2
Connection Layout

F-DP	V-out	I-out	F-DP	V-out	I-out	F-DP	V-out	I-out	F-DP	V-out	I-out
-45	0.000	4.000	-11	1.259	8.030	23	2.519	12.059	57	3.778	16.089
-44	0.037	4.119	-10	1.296	8.148	24	2.556	12.178	58	3.815	16.207
-43	0.074	4.237	-9	1.333	8.267	25	2.593	12.296	59	3.852	16.326
-42	0.111	4.356	-8	1.370	8.385	26	2.630	12.415	60	3.889	16.444
-41	0.148	4.474	-7	1.407	8.504	27	2.667	12.533	61	3.926	16.563
-40	0.185	4.593	-6	1.444	8.622	28	2.704	12.652	62	3.963	16.681
-39	0.222	4.711	-5	1.481	8.741	29	2.741	12.770	63	4.000	16.800
-38	0.259	4.830	-4	1.519	8.859	30	2.778	12.889	64	4.037	16.919
-37	0.296	4.948	-3	1.556	8.978	31	2.815	13.007	65	4.074	17.037
-36	0.333	5.067	-2	1.593	9.096	32	2.852	13.126	66	4.111	17.156
-35	0.370	5.185	-1	1.630	9.215	33	2.889	13.244	67	4.148	17.274
-34	0.407	5.304	0	1.667	9.333	34	2.926	13.363	68	4.185	17.393
-33	0.444	5.422	1	1.704	9.452	35	2.963	13.481	69	4.222	17.511
-32	0.481	5.541	2	1.741	9.570	36	3.000	13.600	70	4.259	17.630
-31	0.519	5.659	3	1.778	9.689	37	3.037	13.719	71	4.296	17.748
-30	0.556	5.778	4	1.815	9.807	38	3.074	13.837	72	4.333	17.867
-29	0.593	5.896	5	1.852	9.926	39	3.111	13.956	73	4.370	17.985
-28	0.630	6.015	6	1.889	10.044	40	3.148	14.074	74	4.407	18.104
-27	0.667	6.133	7	1.926	10.163	41	3.185	14.193	75	4.444	18.222
-26	0.704	6.252	8	1.963	10.281	42	3.222	14.311	76	4.481	18.341
-25	0.741	6.370	9	2.000	10.400	43	3.259	14.430	77	4.519	18.459
-24	0.778	6.489	10	2.037	10.519	44	3.296	14.548	78	4.556	18.578
-23	0.815	6.607	11	2.074	10.637	45	3.333	14.667	79	4.593	18.696
-22	0.852	6.726	12	2.111	10.756	46	3.370	14.785	80	4.630	18.815
-21	0.889	6.844	13	2.148	10.874	47	3.407	14.904	81	4.667	18.933
-20	0.926	6.963	14	2.185	10.993	48	3.444	15.022	82	4.704	19.052
-19	0.963	7.081	15	2.222	11.111	49	3.481	15.141	83	4.741	19.170
-18	1.000	7.200	16	2.259	11.230	50	3.519	15.259	84	4.778	19.289
-17	1.037	7.319	17	2.296	11.348	51	3.556	15.378	85	4.815	19.407
-16	1.074	7.437	18	2.333	11.467	52	3.593	15.496	86	4.852	19.526
-15	1.111	7.556	19	2.370	11.585	53	3.630	15.615	87	4.889	19.644
-14	1.148	7.674	20	2.407	11.704	54	3.667	15.733	88	4.926	19.763
-13	1.185	7.793	21	2.444	11.822	55	3.704	15.852	89	4.963	19.881
-12	1.222	7.911	22	2.481	11.941	56	3.741	15.970	90	5.000	20.000

Table 1—Analog Output Table

FUNCTIONAL TEST

A desiccant cartridge is included with the DPM-35XRN to functionally test the instrument. Before running the functional test, check the color of the desiccant. It should be bright blue. When the desiccant absorbs water vapor, it turns pink. If the entire tube is pink, replace the cartridge (check the replacement parts list at the end of the manual).

Follow this procedure to test the DPM-35XRN or “dry down” the sensor to have quicker system response:

1. Remove end caps from the cartridge and, using the supplied plastic tubing, connect one end to the blue filter. Make sure the arrows on the desiccant cartridge point in the direction of the air flow.
2. Connect the other end of the desiccant cartridge to the exhaust port, resulting in a closed loop.
3. Set the A-B selector switch in the “A” position.
4. Connect power to the unit. Within 5-10 minutes, the dew point reading should decrease below 0°F.

When used in plastics drying operations, hydrocarbons from the out gas of the plastic resin might condense over time on the sensor. The varnish that forms will slow the response time of the sensing element. Eventually the sensor may have to be replaced; therefore, the filter should not be bypassed and should be replaced regularly. Should the response slow down considerably the unit should be returned for sensor replacement and calibration.

RECALIBRATION

The DPM-35XRN is a microprocessor-based instrument. It has no user calibration adjustments. The unit can be recertified to NIST traceable standards by returning it to Ohmic Instruments. Certification is valid for one year and is recommended on a yearly basis. Calibration consists of a computer based system to program a 9-point calibration curve which is stored in the unit’s EEPROM. The calibration is referenced to a NIST traceable chilled mirror.